

## High Output Current LDO Regulator , High PSRR , Low Dropout, ME6217 Series

### General Description

The ME6217 Series is a positive voltage regulator with a low dropout voltage, high output voltage accuracy, and low current consumption developed based on CMOS technology.

A built-in low on-resistance transistor provides a low dropout voltage and large output current, a built-in overcurrent protector prevents the load current from exceeding the current capacitance of the output transistor. An ON/OFF circuit ensures a long battery life. Compared with the voltage regulators using the conventional CMOS process, a larger variety of capacitors are available, including small ceramic capacitors.

### Typical Application

- Power supply for DVD and CD-ROM drives
- Power supply for personal communication device
- Power supply for battery-powered devices
- Power supply for note PCs

### Typical Application Circuit

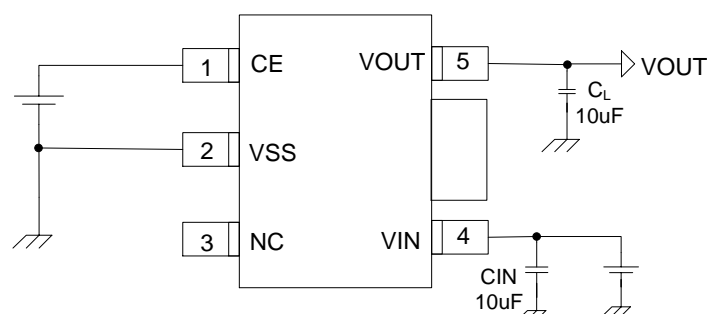

### Features

- Maximum Output Current: 800 mA  
( $V_{IN} \geq V_{OUT}(T) + 1.0V$ )
- Dropout Voltage:  
100mV @  $I_{OUT} = 300mA$ ,  $V_{OUT} = 5.0V$
- Operating Voltage Range: 2V~6.5V
- Output Voltage: 1.5V~5.6V , selectable in 0.1V steps
- Highly Accuracy:  $\pm 1\%$
- Low Current Consumption:  
During Operation: 100uA (TYP.)  
During Shutdown: 0.1uA (TYP.)
- High Ripple Rejection: 65dB@1KHz (ME6217C50)
- Line Regulation: 0.05% (TYP.)
- Thermal Shutdown Protection: 160°C

### Package

- 3-pin: SOT89-3
- 5-pin: SOT89-5, SOT23-5

## Selection Guide

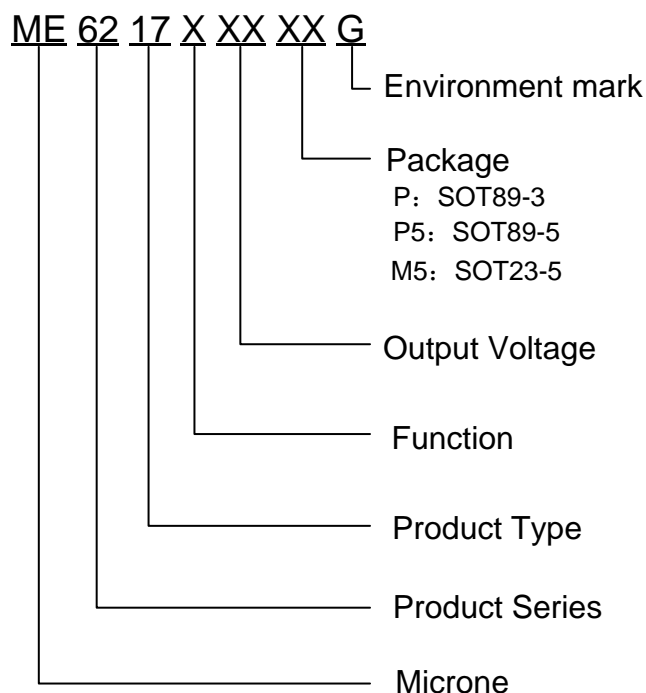

| product series | product description                              |
|----------------|--|
| ME6217A33PG    | $V_{OUT} = 3.3V$ ; without CE; Package: SOT89-3; |
| ME6217C33M5G   | $V_{OUT} = 3.3V$ ; with CE; Package: SOT23-5     |
| ME6217C33P5G   | $V_{OUT} = 3.3V$ ; with CE; Package: SOT89-5     |
| ME6217C39P5G   | $V_{OUT} = 3.9V$ ; with CE; Package: SOT89-5     |
| ME6217C50M5G   | $V_{OUT} = 5.0V$ ; with CE; Package: SOT23-5     |
| ME6217C50P5G   | $V_{OUT} = 5.0V$ ; with CE; Package: SOT89-5     |

**NOTE:** At present ,there are three kinds of voltage value: 3.3V、3.9V、5.0V。  
If you need other voltage and package, please contact our sales staff。

## Pin Configuration

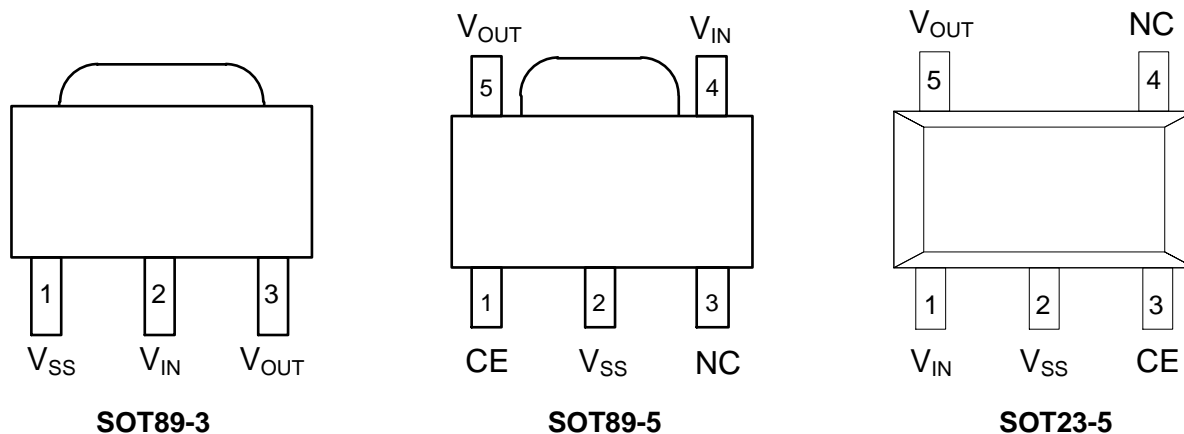

## Pin Assignment

| Pin Num |         |         | Symbol    | Function         |
|---------|---------|---------|-----------|------------------|
| SOT89-3 | SOT89-5 | SOT23-5 |           |                  |
|         | 1       | 3       | CE        | ON / OFF Control |
| 1       | 2       | 2       | $V_{SS}$  | Ground           |
|         | 3       | 4       | NC        | No Connect       |
| 2       | 4       | 1       | $V_{IN}$  | Input Voltage    |
| 3       | 5       | 5       | $V_{OUT}$ | Output Voltage   |

## Block Diagram

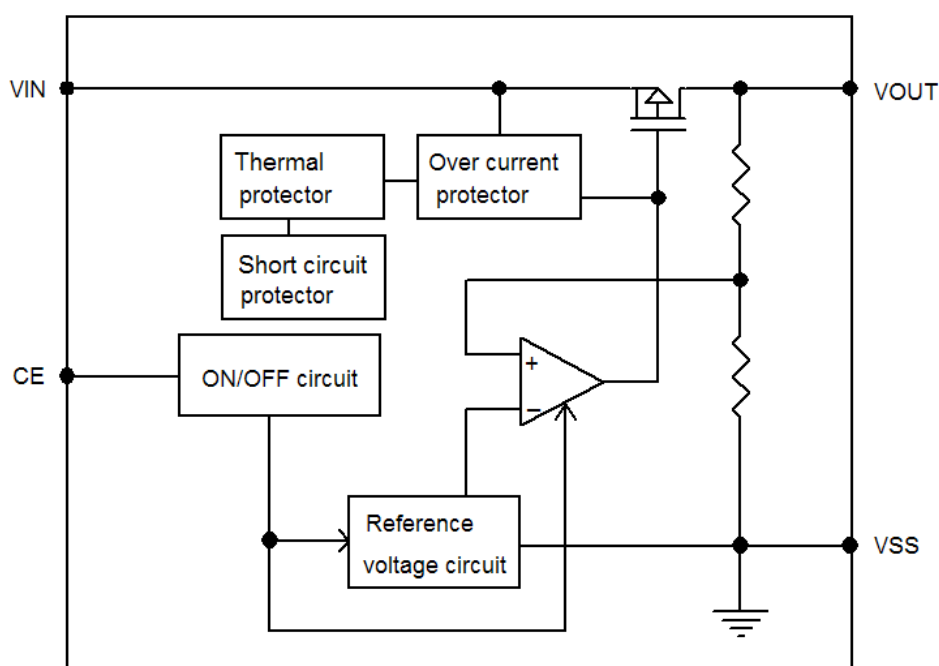

## Absolute Maximum Ratings

| Parameter                               | Symbol    | Ratings                       | Units |      |
|---|-----------|-------------------------------|-------|------|
| Input Voltage                           | $V_{IN}$  | 6.5                           | V     |      |
| Output Voltage                          | $V_{OUT}$ | $V_{SS}-0.3 \sim V_{IN} +0.3$ | V     |      |
| Output Current                          | $I_{OUT}$ | 800                           | mA    |      |
| Operating Ambient Temperature Range     | $T_{OPR}$ | -40 ~ +85                     | °C    |      |
| Storage Temperature Range               | $T_{STG}$ | -55 ~ +150                    | °C    |      |
| Maximum junction temperature            | $T_J$     | -40~+150                      | °C    |      |
| Thermal resistance<br>(Junction to air) | SOT89-3   | $\theta_{JA}$                 | 100   | °C/W |
|   | SOT89-5   |                               | 100   |      |
|   | SOT23-5   |                               | 210   |      |
| Power Dissipation                       | SOT89-3   | $P_D$                         | 1.25  | W    |
|   | SOT89-5   |                               | 1.25  |      |
|   | SOT23-5   |                               | 0.6   |      |

## Electrical Characteristics

**ME6217A33 /ME6217C33** ( $V_{IN} = V_{OUT} (T) + 1.0V$ ,  $V_{CE} = V_{IN}$ ,  $C_{IN}=C_L=10\mu F$ ,  $T_a=25^\circ C$ , unless otherwise noted)

| Parameter                            | Symbol   | Conditions  | Min.   | Typ.                      | Max.   | Units |
|--------------------------------------|--|---|--------|---------------------------|--------|-------|
| Output Voltage                       | $V_{OUT(E)}$<br>(Note 2)                             | $I_{OUT}=100mA$   | X 0.99 | $V_{OUT} (T)$<br>(Note 1) | X 1.01 | V     |
| Input voltage                        | $V_{IN}$   |   | -      | -                         | 6.5    | V     |
| Maximum Output Current               | $I_{OUTMAX}$<br>(Note 4)                             | $V_{IN} \geq V_{OUT} (T) + 1.0V$                                    | -      | 800                       | -      | mA    |
| Load Regulation                      | $\Delta V_{OUT}$                                     | $1mA \leq I_{OUT} \leq 300mA$                                       | -      | 10                        | 50     | mV    |
| Line Regulation                      | $\frac{\Delta V_{OUT}}{\Delta V_{IN} \cdot V_{OUT}}$ | $I_{OUT} = 100mA$<br>$V_{OUT} (T) + 0.5V \leq V_{IN} \leq 6.5V$     | -      | 0.1                       | 0.3    | %/V   |
| Dropout Voltage                      | $V_{DIF}$ (Note 3)                                   | $I_{OUT} = 300mA$   | -      | 100                       | 180    | mV    |
| Current consumption during operation | $I_{SS}$   | no load   | -      | 100                       | 130    | μA    |
| Shutdown current (ME6217C)           | $I_{SD}$   | CE pin = OFF, no load   | -      | 0.1                       | 1.0    | μA    |
| CE "High" Voltage (ME6217C)          | $V_{CEH}$  | Start up, $R_L=1.0K\Omega$  | 1.5    | -                         | -      | V     |
| CE "Low" Voltage (ME6217C)           | $V_{CEL}$  | Shut down, $R_L=1.0K\Omega$   | -      | -                         | 0.3    | V     |
| CE "High" Current (ME6217C)          | $I_{CEH}$  | $V_{IN}=6.0V, V_{CE}=6.0V$  | -0.1   | -                         | 0.1    | μA    |
| CE "Low" Current (ME6217C)           | $I_{CEL}$  | $V_{IN}=6.0V, V_{CE}=0V$  | -0.1   | -                         | 0.1    | μA    |
| Ripple Rejection Rate                | RR   | $V_{IN}=6V, \Delta V_{rip}=0.5V_{rms}$ ,<br>$I_{OUT}=100mA, f=1kHz$ | -      | 65                        | -      | dB    |
| Short-circuit current                | $I_{short}$  | $V_{OUT} = 0 V$   | -      | 350                       | -      | mA    |
| Thermal Shutdown Protection          | $T_{sd}$   | $I_{OUT}=1mA, V_{IN}= V_{OUT}+1V$                                   |        | 160                       |        | °C    |

**ME6217C39** ( $V_{IN} = V_{OUT} (T) + 1.0V$ ,  $V_{CE} = V_{IN}$ ,  $C_{IN}=C_L=10\mu F$ ,  $T_a=25^\circ C$ , unless otherwise noted)

| Parameter      | Symbol                   | Conditions      | Min.   | Typ.                      | Max.   | Units |
|----------------|--------------------------|-----------------|--------|---------------------------|--------|-------|
| Output Voltage | $V_{OUT(E)}$<br>(Note 2) | $I_{OUT}=100mA$ | X 0.99 | $V_{OUT} (T)$<br>(Note 1) | X 1.01 | V     |

|                                      |  |  |      |     |     |             |
|--------------------------------------|--|--|------|-----|-----|-------------|
| Input voltage                        | $V_{IN}$   |  | -    | -   | 6.5 | V           |
| Maximum Output Current               | $I_{OUTMAX}$<br>(Note 4)                             | $V_{IN} \geq V_{OUT}(T) + 1.0V$  | -    | 800 | -   | mA          |
| Load Regulation                      | $\Delta V_{OUT}$                                     | $1mA \leq I_{OUT} \leq 300mA$  | -    | 10  | 50  | mV          |
| Line Regulation                      | $\frac{\Delta V_{OUT}}{\Delta V_{IN} \cdot V_{OUT}}$ | $I_{OUT} = 100mA$<br>$V_{OUT}(T) + 0.5V \leq V_{IN} \leq 6.5V$             | -    | 0.1 | 0.3 | %/V         |
| Dropout Voltage                      | $V_{DIF}$ (Note 3)                                   | $I_{OUT} = 300mA$  | -    | 100 | 180 | mV          |
| Current consumption during operation | $I_{SS}$   | no load  | -    | 100 | 130 | $\mu A$     |
| Shutdown current                     | $I_{SD}$   | CE pin = OFF no load   | -    | 0.1 | 1.0 | $\mu A$     |
| CE "High" Voltage                    | $V_{CEH}$  | Start up, $R_L = 1.0K\Omega$   | 1.5  | -   | -   | V           |
| CE "Low" Voltage                     | $V_{CEL}$  | Shut down, $R_L = 1.0K\Omega$  | -    | -   | 0.3 | V           |
| CE "High" Current                    | $I_{CEH}$  | $V_{IN} = 6.0V, V_{CE} = 6.0V$   | -0.1 | -   | 0.1 | $\mu A$     |
| CE "Low" Current                     | $I_{CEL}$  | $V_{IN} = 6.0V, V_{CE} = 0V$   | -0.1 | -   | 0.1 | $\mu A$     |
| Ripple Rejection Rate                | RR   | $V_{IN} = 6V, \Delta V_{rip} = 0.5V_{rms}, I_{OUT} = 100mA,$<br>$f = 1kHz$ | -    | 65  | -   | dB          |
| Short-circuit current                | $I_{short}$  | $V_{OUT} = 0V$   | -    | 350 | -   | mA          |
| Thermal Shutdown Protection          | $T_{sd}$   | $I_{OUT} = 1mA, V_{IN} = V_{OUT} + 1V$                                     | -    | 160 | -   | $^{\circ}C$ |

**ME6217C50** ( $V_{IN} = V_{OUT}(T) + 1.0V$ ,  $V_{CE} = V_{IN}$ ,  $C_{IN} = C_L = 10\mu F$ ,  $T_a = 25^{\circ}C$ , unless otherwise noted)

| Parameter                            | Symbol   | Conditions   | Min.   | Typ.                     | Max.   | Units   |
|--------------------------------------|--|--|--------|--------------------------|--------|---------|
| Output Voltage                       | $V_{OUT(E)}$<br>(Note 2)                             | $I_{OUT} = 100mA$  | X 0.99 | $V_{OUT}(T)$<br>(Note 1) | X 1.01 | V       |
| Input voltage                        | $V_{IN}$   |  | -      | -                        | 6.5    | V       |
| Maximum Output Current               | $I_{OUTMAX}$<br>(Note 4)                             | $V_{IN} \geq V_{OUT}(T) + 1.0V$                                | -      | 800                      | -      | mA      |
| Load Regulation                      | $\Delta V_{OUT}$                                     | $1mA \leq I_{OUT} \leq 300mA$                                  | -      | 10                       | 50     | mV      |
| Line Regulation                      | $\frac{\Delta V_{OUT}}{\Delta V_{IN} \cdot V_{OUT}}$ | $I_{OUT} = 100mA$<br>$V_{OUT}(T) + 0.5V \leq V_{IN} \leq 6.5V$ | -      | 0.1                      | 0.3    | %/V     |
| Dropout Voltage                      | $V_{DIF}$ (Note 3)                                   | $I_{OUT} = 300mA$  | -      | 100                      | 180    | mV      |
| Current consumption during operation | $I_{SS}$   | no load  | -      | 100                      | 130    | $\mu A$ |
| Shutdown current                     | $I_{SD}$   | CE pin = OFF, no load  | -      | 0.1                      | 1.0    | $\mu A$ |
| CE "High" Voltage                    | $V_{CEH}$  | Start up, $R_L = 1.0K\Omega$                                   | 1.5    | -                        | -      | V       |
| CE "Low" Voltage                     | $V_{CEL}$  | Shut down, $R_L = 1.0K\Omega$                                  | -      | -                        | 0.3    | V       |
| CE "High" Current                    | $I_{CEH}$  | $V_{IN} = 6.0V, V_{CE} = 6.0V$                                 | -0.1   | -                        | 0.1    | $\mu A$ |
| CE "Low" Current                     | $I_{CEL}$  | $V_{IN} = 6.0V, V_{CE} = 0V$                                   | -0.1   | -                        | 0.1    | $\mu A$ |

|                             |             |  |   |     |   |    |
|-----------------------------|-------------|--|---|-----|---|----|
| Ripple Rejection Rate       | RR          | $V_{IN}=6V, \Delta V_{rip}=0.5V_{rms}, I_{OUT}=100mA,$<br>$f=1kHz$ | - | 65  | - | dB |
| Short-circuit current       | $I_{short}$ | $V_{OUT} = 0 V$  | - | 350 | - | mA |
| Thermal Shutdown Protection | $T_{sd}$    | $I_{OUT}=1mA, V_{IN}= V_{OUT}+1V$                                  | - | 160 | - | °C |

Note :

1.  $V_{OUT}(T)$  : Specified Output Voltage
2.  $V_{OUT}(E)$  : Effective Output Voltage ( i.e. The output voltage when " $V_{OUT}(T)+1.0V$ " is provided at the  $V_{in}$  pin while maintaining a certain  $I_{out}$  value.)
3.  $V_{DIF}: V_{IN1} - V_{OUT}(E)'$   
 $V_{IN1}$  : The input voltage when  $V_{OUT}(E)'$  appears as input voltage is gradually decreased.  
 $V_{OUT}(E)'$  = A voltage equal to 98% of the output voltage whenever an amply stabilized  $I_{out} \{V_{OUT}(T)+1.0V\}$  is input.
4.  $I_{OUTMAX}$ : Due to restrictions on the package power dissipation, this value may not be satisfied. Attention should be paid to the power dissipation of the package when the output current is large. This specification is guaranteed by design.

## Operation

### 1. Basic operation

Figure 1 shows the block diagram of the ME6217 Series.

The error amplifier compares the reference voltage ( $V_{ref}$ ) with  $V_{fb}$ , which is the output voltage resistance-divided by feedback resistors  $R_s$  and  $R_f$ . It supplies the output transistor with the gate voltage necessary to ensure a certain output voltage free of any fluctuations of input voltage and temperature.

### 2. Output transistor

The ME6217 Series uses a low on-resistance P-channel MOS FET as the output transistor. Be sure that  $V_{OUT}$  does not exceed  $V_{IN} + 0.3\text{ V}$  to prevent the voltage regulator from being damaged due to inverse current flowing from  $V_{OUT}$  pin through a parasitic diode to  $V_{IN}$  pin.

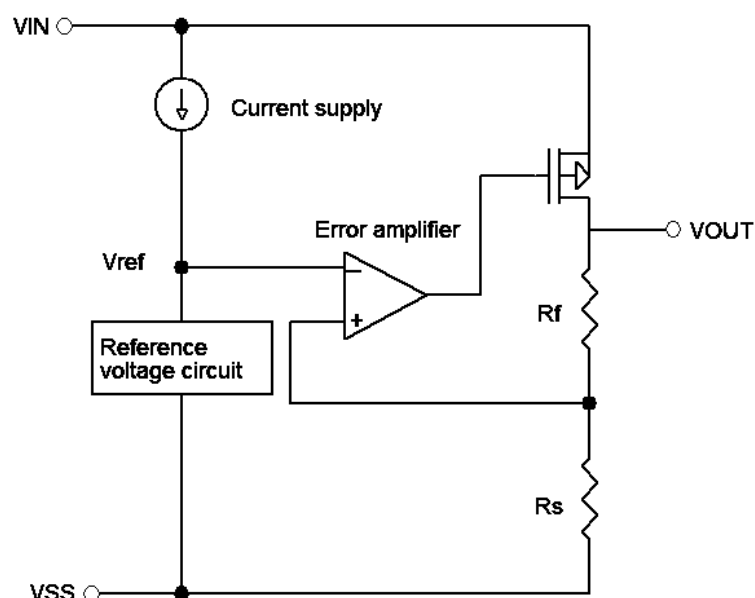

Figure 1

### 3. Shutdown pin (CE pin)

This pin starts and stops the regulator.

When the CE pin is set to the shutdown level, the operation of all internal circuits stops, and the built-in P-channel MOS FET output transistor between the  $V_{IN}$  pin and  $V_{OUT}$  pin is turned off to substantially reduce the current consumption. The  $V_{OUT}$  pin becomes the  $V_{SS}$  level due to the internally divided resistance of several hundreds  $k\Omega$  between the  $V_{OUT}$  pin and  $V_{SS}$  pin. Since the CE pin is neither pulled down nor pulled up internally, do not use it in the floating state. In addition, note that the current consumption increases if a voltage of  $0.3\text{ V}$  to  $V_{IN} - 0.3\text{ V}$  is applied to the CE pin.

Table 1

| CE Pin        | Internal Circuits | $V_{OUT}$ Pin Voltage | Current Consumption |
|---------------|-------------------|-----------------------|---------------------|
| "H" Power on  | Operating         | Set value             | $I_{SS1}$           |
| "L" Power off | Stopped           | $V_{SS}$ level        | $I_{SS2}$           |

## Precautions

1. Wiring patterns for the VIN, VOUT and GND pins should be designed so that the impedance is low. When mounting an output capacitor between the VOUT and VSS pins (CL) and a capacitor for stabilizing the input between VIN and VSS pins (CIN), the distance from the capacitors to these pins should be as short as possible.
2. Note that the output voltage may increase when a series regulator is used at low load current (1.0 mA or less).
3. Generally a series regulator may cause oscillation, depending on the selection of external parts. The following conditions are recommended for this IC. However, be sure to perform sufficient evaluation under the actual usage conditions for selection, including evaluation of temperature characteristics.

Input capacitor (CIN): 4.7  $\mu$ F or more

Output capacitor (CL): 4.7  $\mu$ F or more

Equivalent series resistance (ESR): 0.5  $\Omega$  or less

4. The voltage regulator may oscillate when the impedance of the power supply is high and the input capacitor is small or an input capacitor is not connected.
5. The application conditions for the input voltage, output voltage, and load current should not exceed the package power dissipation.
6. Do not apply an electrostatic discharge to this IC that exceeds the performance ratings of the built-in electrostatic protection circuit.
7. SII claims no responsibility for any disputes arising out of or in connection with any infringement by products including this IC of patents owned by a third party.

## Type Characteristics

- (1) Input Voltage VS. Output Voltage ( $T_a = 25^\circ\text{C}$ )  
ME6217C50P5G

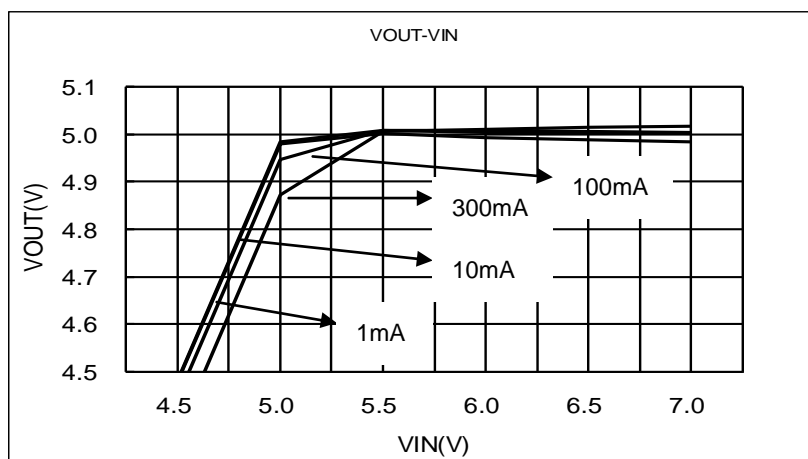



- (2) Output Current VS. Dropout Voltage ( $V_{IN} = V_{OUT}(T) + 1.0V, T_a = 25^\circ C$ )  
ME6217C50P5G

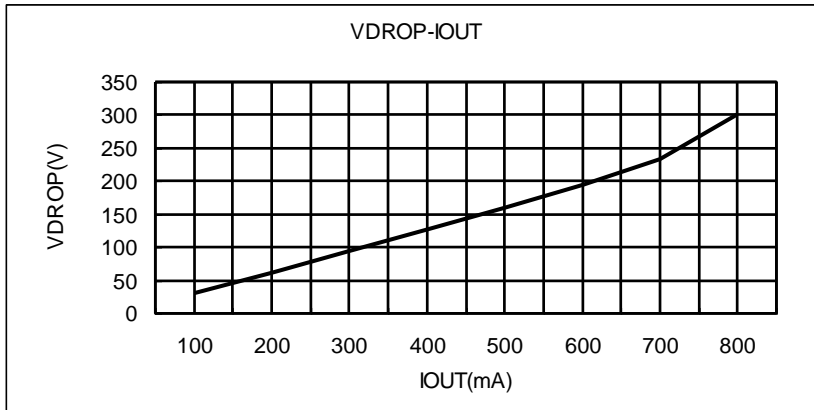

- (3) Input Voltage VS. Current Consumption ( $T_a = 25^\circ C$ )  
ME6217C50P5G

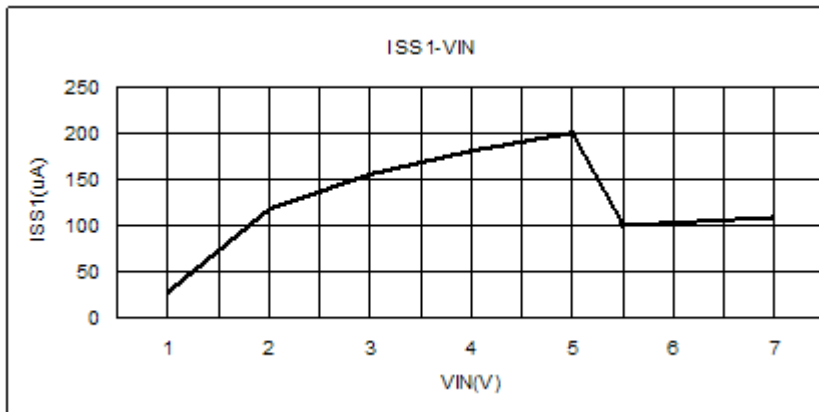

- (4) Dropout Voltage VS. Output Current  
ME6217C33P5G

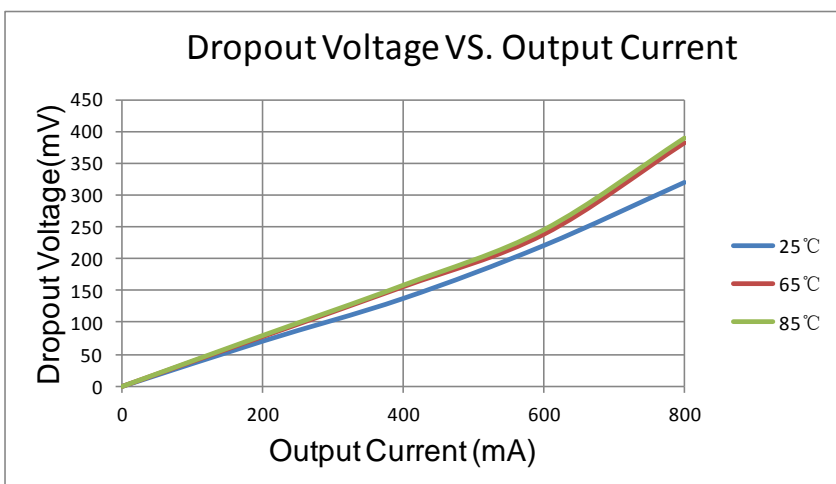

## Packaging Information

- Packaging Type: SOT89-3

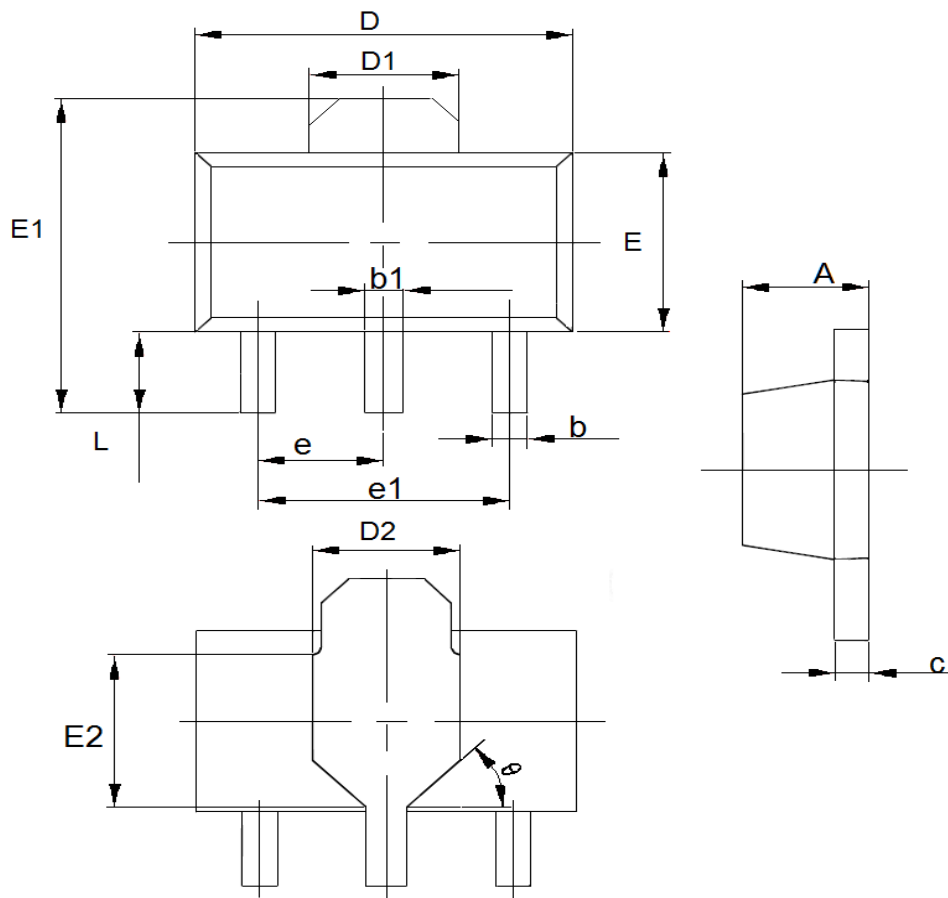

| DIM | Millimeters |      | Inches      |        |
|-----|-------------|------|-------------|--------|
|     | Min         | Max  | Min         | Max    |
| A   | 1.4         | 1.6  | 0.0551      | 0.0630 |
| b   | 0.32        | 0.52 | 0.0126      | 0.0205 |
| b1  | 0.4         | 0.58 | 0.0157      | 0.0228 |
| c   | 0.35        | 0.45 | 0.0138      | 0.0177 |
| D   | 4.4         | 4.6  | 0.1732      | 0.1811 |
| D1  | 1.55(TYP)   |      | 0.061(TYP)  |        |
| D2  | 1.75(TYP)   |      | 0.0689(TYP) |        |
| e1  | 3.0(TYP)    |      | 0.1181(TYP) |        |
| E   | 2.3         | 2.6  | 0.0906      | 0.1023 |
| E1  | 3.94        | 4.4  | 0.1551      | 0.1732 |
| E2  | 1.9(TYP)    |      | 0.0748(TYP) |        |
| e   | 1.5(TYP)    |      | 0.0591(TYP) |        |
| L   | 0.8         | 1.2  | 0.0315      | 0.0472 |
| θ   | 45°         |      | 45°         |        |

● Packaging Type: SOT89-5

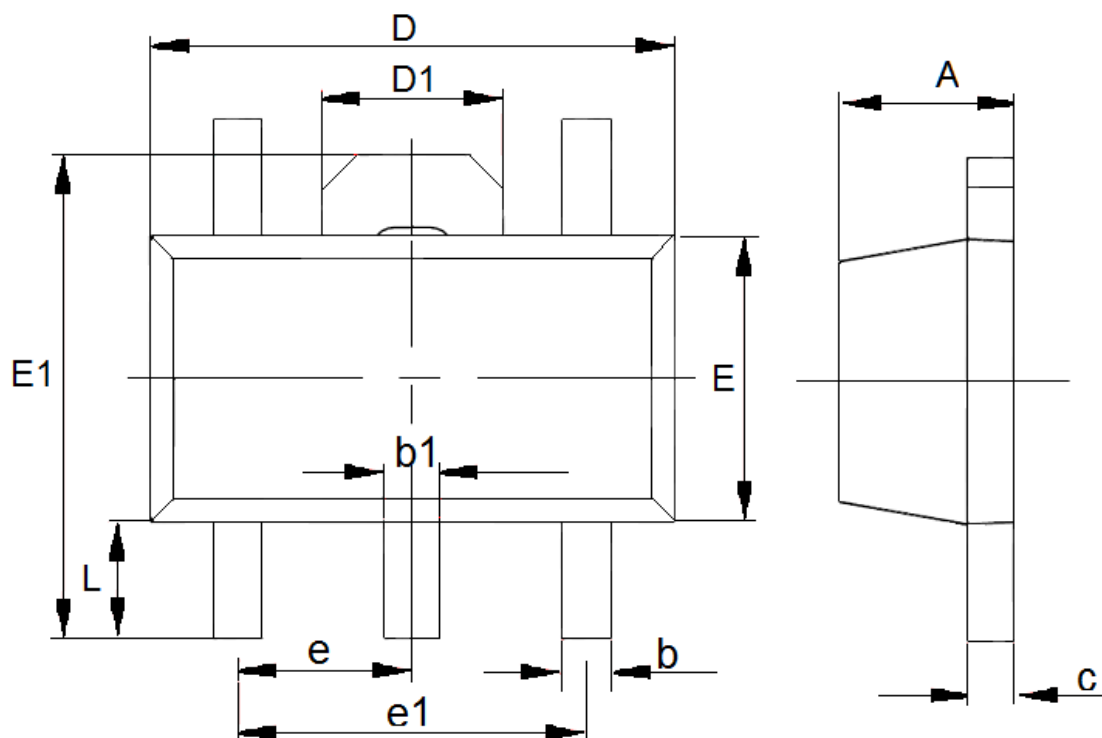

| DIM | Millimeters |      | Inches      |        |
|-----|-------------|------|-------------|--------|
|     | Min         | Max  | Min         | Max    |
| A   | 1.4         | 1.6  | 0.0551      | 0.0630 |
| b   | 0.32        | 0.52 | 0.0126      | 0.0205 |
| b1  | 0.38        | 0.58 | 0.0150      | 0.0228 |
| c   | 0.35        | 0.47 | 0.0138      | 0.0185 |
| D   | 4.4         | 4.6  | 0.1732      | 0.1811 |
| D1  | 1.55(TYP)   |      | 0.061(TYP)  |        |
| e1  | 3(TYP)      |      | 0.1181(TYP) |        |
| E   | 2.3         | 2.6  | 0.0906      | 0.1023 |
| E1  | 3.94        | 4.4  | 0.1551      | 0.1732 |
| e   | 1.5(TYP)    |      | 0.0591(TYP) |        |
| L   | 0.8         | 1.2  | 0.0315      | 0.0472 |

● Packaging Type: SOT23-5

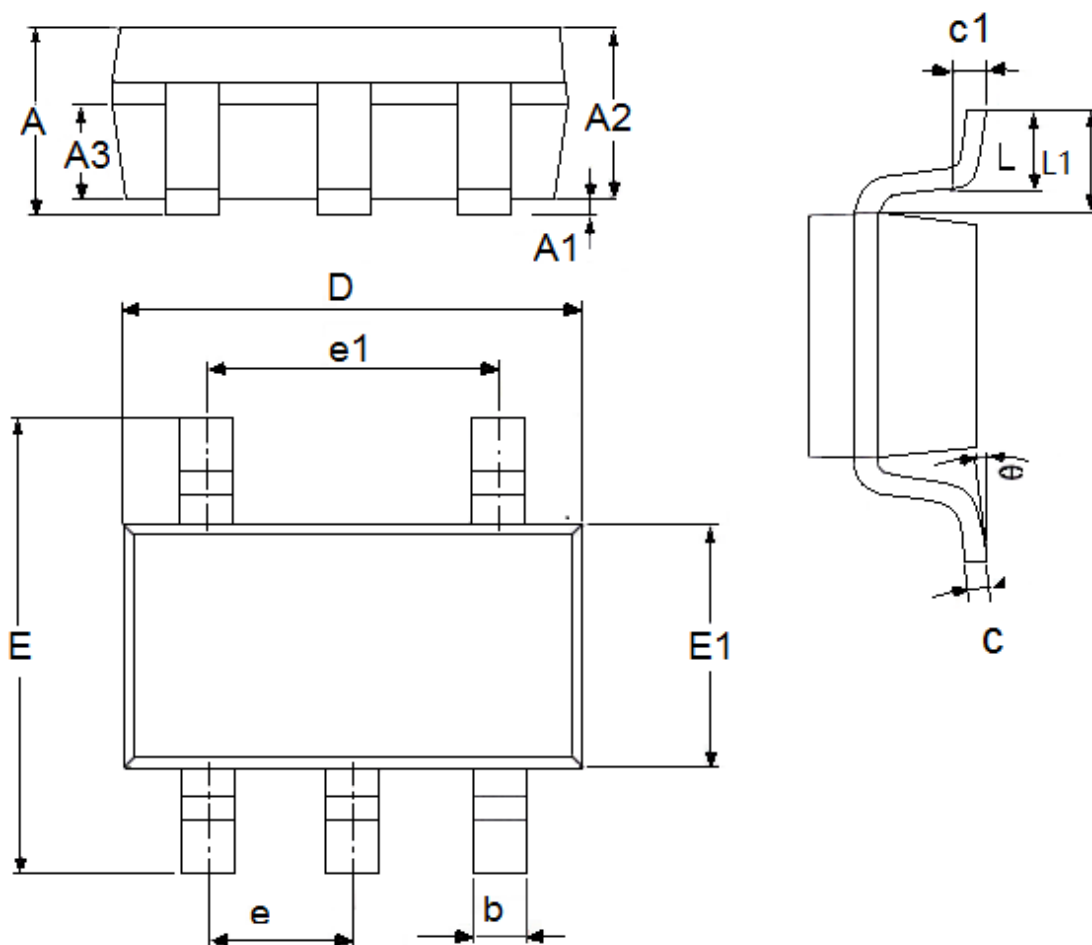

| DIM      | Millimeters |      | Inches      |        |
|----------|-------------|------|-------------|--------|
|          | Min         | Max  | Min         | Max    |
| A        | 1.05        | 1.45 | 0.0413      | 0.0571 |
| A1       | 0           | 0.15 | 0.0000      | 0.0059 |
| A2       | 0.9         | 1.3  | 0.0354      | 0.0512 |
| A3       | 0.6         | 0.7  | 0.0236      | 0.0276 |
| b        | 0.25        | 0.5  | 0.0098      | 0.0197 |
| c        | 0.1         | 0.23 | 0.0039      | 0.0091 |
| D        | 2.82        | 3.05 | 0.1110      | 0.1201 |
| e1       | 1.9(TYP)    |      | 0.0748(TYP) |        |
| E        | 2.6         | 3.05 | 0.1024      | 0.1201 |
| E1       | 1.5         | 1.75 | 0.0512      | 0.0689 |
| e        | 0.95(TYP)   |      | 0.0374(TYP) |        |
| L        | 0.25        | 0.6  | 0.0098      | 0.0236 |
| L1       | 0.59(TYP)   |      | 0.0232(TYP) |        |
| $\theta$ | 0           | 8°   | 0.0000      | 8°     |
| c1       | 0.2(TYP)    |      | 0.0079(TYP) |        |

- The contents of this document will be updated with the product's improvement without prior notice. Please consult our sales staff before using this document to ensure that you are using the latest version.
- The application circuit examples described in this document are only used to indicate the representative use of the product and do not guarantee the design of mass production.
- Please use this product within the limits stated in this document. We will not be responsible for any damage caused by improper use.
- The products described in this document are not allowed to be used in equipment or devices that affect the human body without the written permission of our company, including but not limited to: health equipment, medical equipment, disaster prevention equipment, fuel control equipment, automobile equipment, aviation equipment and vehicle equipment.
- Although our company has always been committed to improving product quality and reliability, semiconductor products have a certain probability of malfunction or wrong work. To prevent personal injury or property damage caused by such accidents, please pay full attention to safety design, for example: Alternate design, fire protection design, and prevention of wrong action design.
- When exporting this product or this document overseas, you should abide by applicable import and export control laws.
- Copying or reprinting part or all of this document in any form without the permission of our company is strictly prohibited.