

DESCRIPTION

The CM6635 is a USB 2.0 high speed audio controller that complies with USB Audio Device Class 2.0. The CM6635 provides standard I2S and S/PDIF digital audio interface. The maximum outputs are 6 channels with 4 channels I2S and 2 channels S/PDIF and the maximum inputs are 6 channels with 4 channels I2S and 2 channels S/PDIF. The first I2S interface can be used to transfer PCM and DSD audio data. Moreover, the CM6635 supports I2C, SPI and GPIOs to communicate with external device.

The CM6635 is embedded with 8051 MCU and 512KB flash makes it is very flexible to change the USB topology or communicate with external device by changing internal flash code.

FEATURES

- Compliant with USB 2.0 high-speed
- Compliant with USB Audio Device Class 2.0/1.0
- Compliant with USB Human Interface Device (HID) Class 1.1
- Supports USB suspend/resume/reset functions
- Supports control, interrupt, bulk, and isochronous data transfers
- USB audio is asynchronous synchronization to reduce clock jitter
- 2 stereo I2S serial audio output interfaces
- The first I2S output supports up to 768KHz/32bits PCM
- The first I2S supports both DoP and Native DSD
- DoP up to 11.2MHz, DSD256
- Native DSD up to 22.4MHz, DSD512
- 2 stereo I2S serial audio input interfaces
- The first I2S input supports up to 384KHz/32bits
- S/PDIF input and output up to 192K/24bits
- 1 I2C master, 1 I2C slave, 1 SPI master, 18 GPIOs

BLOCK DIAGRAM

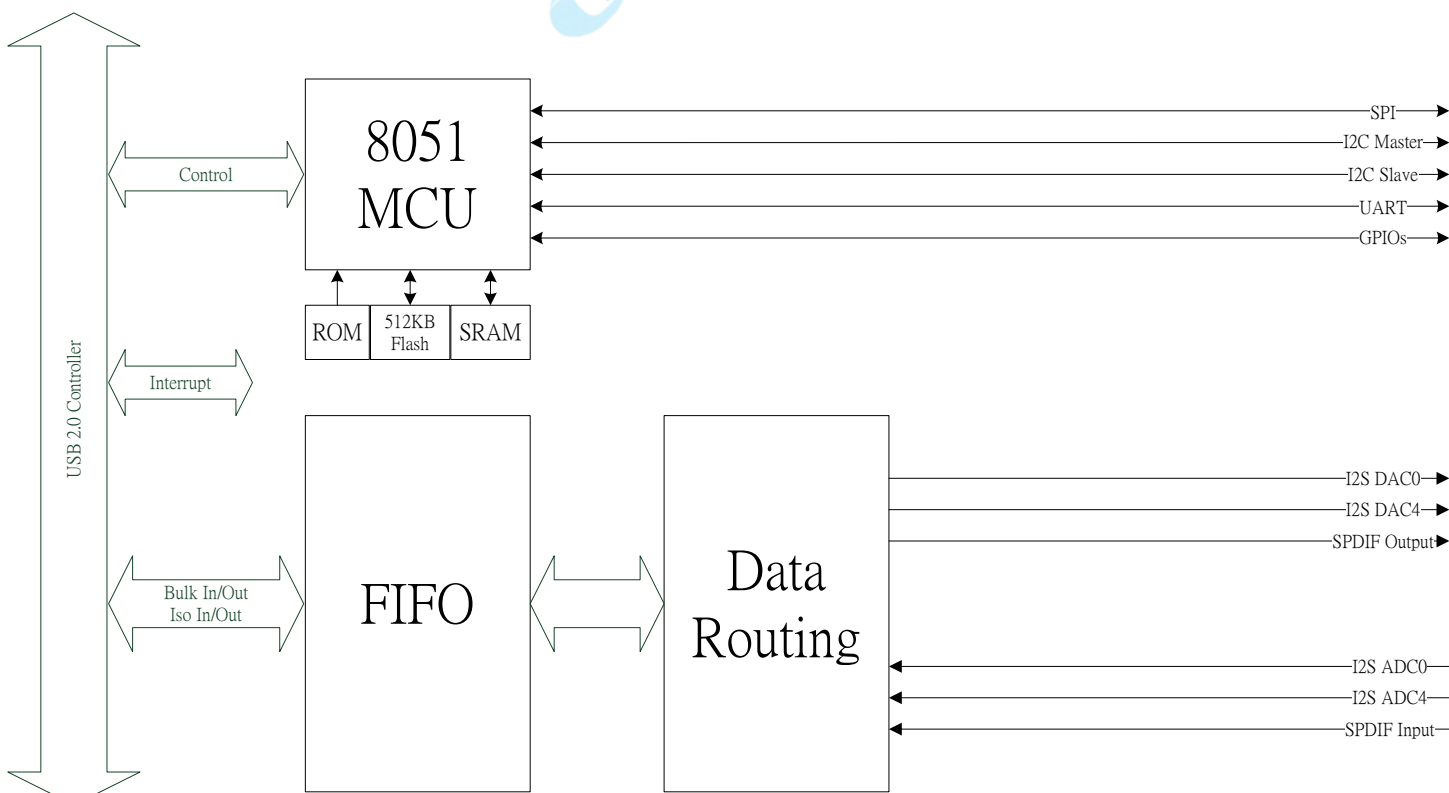

Release notes

Revision	Date	Description
0.9	2018/09/12	- First release of preliminary technical information
0.91	2019/09/27	- Add more information
1.0	2020/05/21	- Formal Release

昂纬科技
ONWAY

TABLE OF CONTENTS

1	DESCRIPTION AND OVERVIEW	5
2	ORDERING INFORMATION	5
3	FEATURES	5
3.1	USB COMPLIANCE	5
3.2	DIGITAL AUDIO I/O	5
3.3	INTEGRATED 8051 MICRO PROCESSOR	6
3.4	CONTROL INTERFACE	6
3.5	GENERAL.....	6
3.6	OPTIONAL VALUE-ADDED SOFTWARE FEATURES.....	6
4	APPLICATIONS	7
5	BLOCK DIAGRAM	7
6	PIN ASSIGNMENT	8
6.1	PIN-OUT DIAGRAM	8
6.2	PIN DESCRIPTION.....	9
7	FUNCTION DESCRIPTION	13
7.1	USB TOPOLOGY	13
7.2	USB ENDPOINT	13
7.3	I2S INTERFACE	13
7.3.1	<i>The Basics of I2S Bus</i>	13
7.3.2	<i>Left Justified Mode</i>	14
7.3.3	<i>I2S Mode</i>	15
7.4	S/PDIF INTERFACE.....	15
7.5	I2C, TWO-WIRE INTERFACE.....	17
7.5.1	<i>The Concept of I2C, Two Wire Interface</i>	17
7.5.2	<i>Start and Stop Condition</i>	18
7.5.3	<i>Bit Transfer</i>	18
7.5.4	<i>Transferring Data with Read/Write Transactions and Acknowledge</i>	19
7.5.5	<i>Synchronization</i>	21
7.5.6	<i>Standard Mode and Fast Mode</i>	22
7.6	SPI INTERFACE	22
7.6.1	<i>The SPI128 interface Typical Transfer</i>	23
7.7	GPIO	24
8	ELECTRICAL CHARACTERISTICS	24

8.1	ABSOLUTE MAXIMUM RATINGS	24
8.1	RECOMMENDED OPERATION CONDITIONS	24
8.2	POWER CONSUMPTION	25
8.3	DC CHARACTERISTICS	25
9	PACKAGE DIMENSIONS.....	26



1 Description and Overview

The CM6635 is a USB 2.0 high speed audio controller that complies with USB Audio Device Class 2.0. The CM6635 provides standard I2S and S/PDIF digital audio interface. The maximum outputs are 6 channels with 4 channels I2S and 2 channels S/PDIF and the maximum inputs are 6 channels with 4 channels I2S and 2 channels S/PDIF. The first I2S interface can be used to transfer PCM and DSD audio data. Moreover, the CM6635 supports I2C, SPI and GPIOs to communicate with external device.

The CM6635 is embedded with 8051 MCU and 512KB flash makes it is very flexible to change the USB topology or communicate with external device by changing internal flash code.

2 Ordering Information

Product	Package Marking	Package Type	Transport Media	Storage Temperature
CM6635	CM6635	QFN-64(7.5x7.5mm)	Tray	

3 Features

3.1 USB Compliance

- Compliant with USB 2.0 high-speed
- Compliant with USB Audio Device Class 2.0/1.0
- Compliant with USB Human Interface Device (HID) Class 1.1
- Supports USB suspend/resume/reset functions
- Supports control, interrupt, bulk, and isochronous data transfers
- USB audio is asynchronous synchronization to reduce clock jitter

3.2 Digital Audio I/O

- 2 stereo I2S serial audio and 1 S/PDIF output interfaces, refer below [Table 1](#) for each audio format support
- 2 stereo I2S serial audio and 1 S/PDIF input interfaces, refer below [Table 1](#) for each audio format support
- All the I2S in/out support master and slave

Table 1 (USB Audio Class 2.0)

Interface	Audio Format		Bit Depth
I2S DAC0	PCM	768K/705.6K/384K/352.8K/192K/ 176.4K/96K/88.2K/64K/48K/44.1K/32K/16K/8K Hz	16/24/32 bits
	DSD	DoP: 2.8/5.6/11.2MHz Native: 2.8/5.6/11.2/22.4MHz	
I2S DAC4	PCM	192K/ 176.4K/96K/88.2K/64K/48K/44.1K/32K/16K/8K Hz	16/24 bits
S/PDIF Out	PCM	192K/ 176.4K/96K/88.2K/64K/48K/44.1K/32K	16/24 bits
		AC3, DTS Compressed audio data	
I2S ADC0	PCM	384K/352.8K/192K/ 176.4K/96K/88.2K/64K/48K/44.1K/32K/16K/8K Hz	16/24/32 bits
I2S ADC4	PCM	192K/ 176.4K/96K/88.2K/64K/48K/44.1K/32K/16K/8K Hz	16/24 bits

S/PDIF In	PCM	192K/ 176.4K/96K/88.2K/64K/48K/44.1K/32K	16/24 bits
--------------	-----	--	------------

Note: DAC0 doesn't support I2S Slave mode.

3.3 Integrated 8051 Micro Processor

- Embedded 8051 micro-processor handles the USB transfers(control, isochronous, interrupt, and bulk)
- Communicate with external peripheral devices(I2C, I2S, SPI, GPIO, etc.)
- The MCU speed is programmable from 3.072 ~65.536 MHz
- HID interrupts can be implemented via firmware codes
- Provides maximum HW configuration flexibility with a firmware code upgrade
- VID/PID/product string can be customized via firmware code programming

3.4 Control Interface

- 1 Master I2C control interface to communicate with external devices or EEPROM, the master I2C speed supports standard mode(100KHz) and fast mode(400KHz)
- 1 Slave I2C control interface for external MCU communication, the slave I2C speed supports standard mode(100KHz) and fast mode(400KHz)
- 1 SPI master, supports speed from 32.768M ~ 0.3695Mb/s
- 1 UART
- 18 GPIOs(programmable multi functions I/O), 6 XDs(can be GPIO or other functions)
- 6 PWM LED driver output

3.5 General

- Embedded USB 2.0 transceiver and power-on reset circuit.
- Bus-power and self-power options
- Single 12MHz crystal input is required (embedded PLL function), or optional oscillator inputs for 49.152 or 24.576MHz (for x48KHz audio format) and 45.158 or 22.5792MHz (for x44.1KHz audio format)
- 12 MHz clock output for external devices.
- Single 5V power supply with embedded 5V to 3.3V regulator.
- Auto detection for high-speed/full-speed
- 3.3V digital I/O pads with 5V tolerance
- Compliant with USB IF certification requirements.
- QFN-64 package (7.5 x 7.5 mm)

3.6 Optional Value-added Software Features

- For Windows, Cmedia drivers provide the following key features:
 - Playback feedback endpoints to control data transmission accuracy and maximize audio quality
 - Xear™ Pro- ASIO2.2 driver
 - Native DSD by ASIO

4 Applications

- USB DAC
- USB Headphone Amplifier
- Professional audio-PC musician applications (recording mixer, I/O interface, DJ console, keyboard, Electric guitar, etc.)

5 Block Diagram

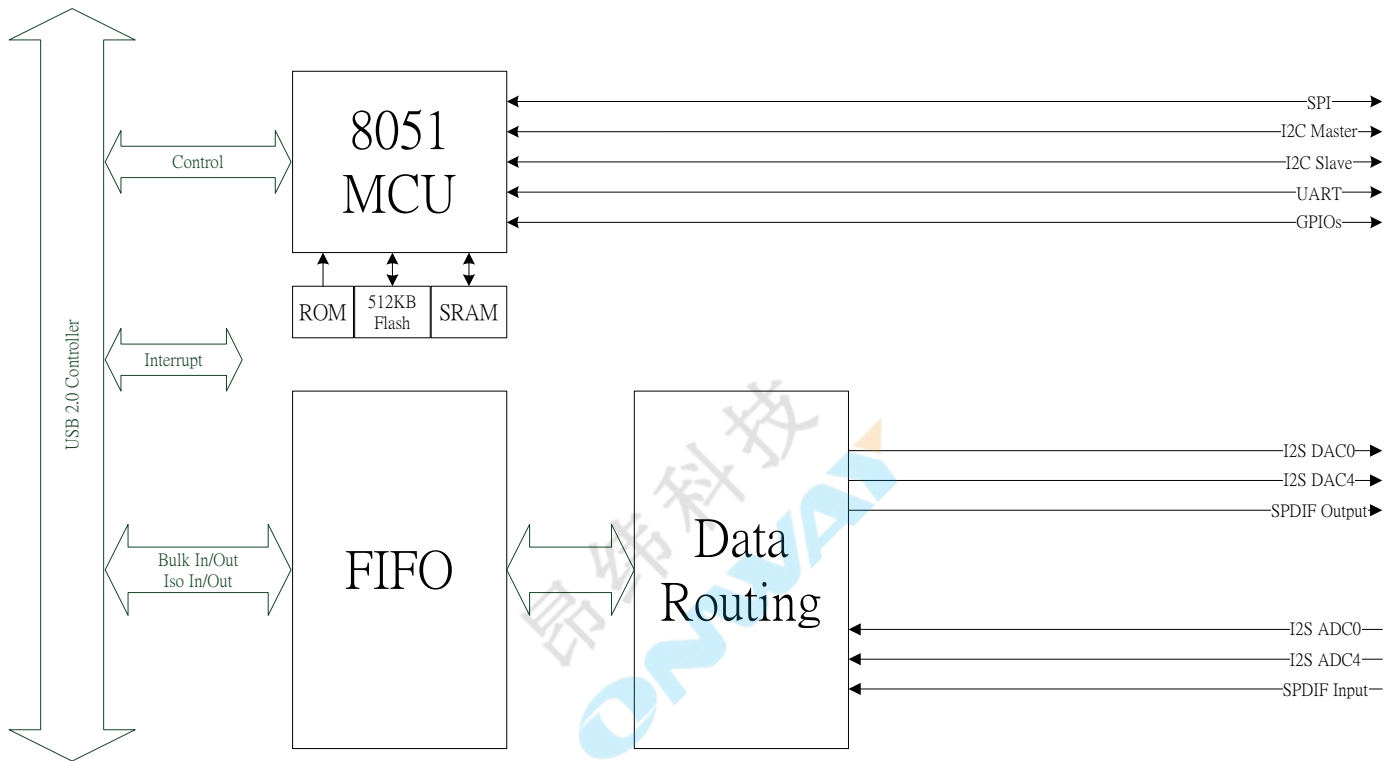

CM6635 Functional Block Diagram

6 Pin Assignment

6.1 Pin-out Diagram

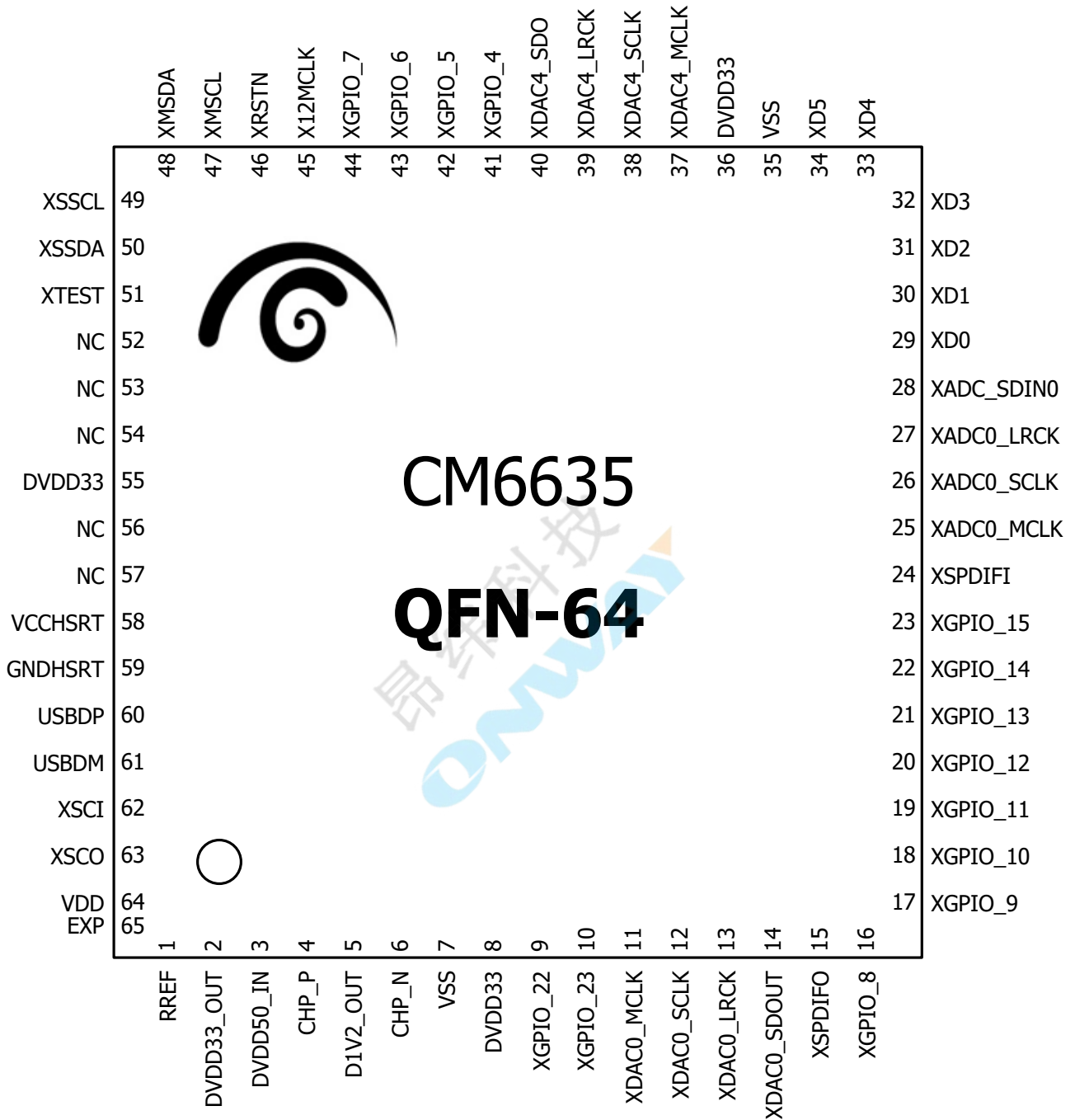

6.2 Pin Description

Pin #	Symbol	I/O	Description
Clock			
45	X12M_CLK	DO	12MHz clock output
62	XSCI	AI	Crystal oscillator input
63	XSCO	AO	Crystal oscillator output
USB 2.0 BUS Interface			
1	RREF	AI	USB PHY reference resistor. Connect external reference resistor (330Ω±1%)
60	USB_DP	AIO	USB 2.0 data positive
61	USB_DM	AIO	USB 2.0 data negative
Power/Ground			
2	DVDD33_OUT	PWR	Digital supply voltage 3.3V
3	DVDD50_IN	PWR	Digital supply voltage 5V for digital circuit linear regulator
4	CHP_P	-	Charge-pump positive output, connected to a 2.2uF capacitor
5	D1V2_OUT	PWR	DC-DC 1.2V output
6	CHP_N	-	Charge-pump negative output, connected to a 2.2uF capacitor
7	VSS	GND	Digital ground supply
8	DVDD33	PWR	Digital supply voltage 3.3V
35	VSS	GND	Digital ground supply
36	DVDD33	PWR	Digital supply voltage 3.3V
55	DVDD33	PWR	Digital supply voltage 3.3V
58	VCCHSRT	PWR	Digital supply voltage 3.3V
59	GNDHSRT	GND	Digital ground supply
64	VDD	PWR	Digital supply voltage 1.2V, connected to the capacitor filter for digital core
65	EXP	GND	Ground paddle
2 Channel I2S DAC0 Interface			
11	XDAC0_MCLK	DO	1). I2S DAC0 master clock output 2). DSD bit clock output
12	XDAC0_SCLK	DIO	1). I2S DAC0 bit clock input/output 2). DSD bit clock output
13	XDAC0_LRCK	DIO	1). I2S DAC0 left/right clock input/output 2). DSD channel 1 (or 0, if enable channel switching) data output
14	XDAC0_SDOOUT	DO	1). I2S DAC0 serial data output for channel 0, 1 2). DSD channel 0 (or 1, if enable channel switching) data output
2-channel I2S ADC0 Interface			
25	XADC0_MCLK	DO	I2S ADC0 master clock output
26	XADC0_SCLK	DIO	I2S ADC0 bit clock input/output
27	XADC0_LRCK	DIO	I2S ADC0 left/right clock input/output
28	XADC0_SDIN	DI	I2S ADC0 serial data input for channel 0, 1
S/PDIF I/O			

15	XSPDIFO	DO	S/PDIF transmitter
24	XSPDIFI	DI	S/PDIF receiver
GPIO			
9	XGPIO_22	DIO	1). General purpose input/output 22 (default input) 2). External 24.576 MHz / 49.152 MHz oscillator input
10	XGPIO_23	DIO	1). General purpose input/output 23 (default input) 2). External 22.5792 MHz / 45.1584 MHz oscillator input
16	XGPIO_8	DIO	1). General purpose input/output 8 (default output) 2). SPI Master clock output 3). I2S ADC4 master clock output
17	XGPIO_9	DIO	1). General purpose input/output 9 (default output) 2). SPI Master data output 3). I2S ADC4 bit clock input/output
18	XGPIO_10	DIO	1). General purpose input/output 10 (default input) 2). SPI Master Data input 3). I2S ADC4 left/right clock input/output 4). R8051 serial 1 interface transmit data, TXD1
19	XGPIO_11	DIO	1). General purpose input/output 11 (default input) 2). SPI Master chip enable 6 output 3). R8051 serial 1 interface receive data, RXD1 4). I2S ADC4 serial data input for channel 0, 1
20	GPIO_12	DIO	1). General purpose input/output 12 (default input) 2). LED module 4 Output
21	GPIO_13	DIO	1). General purpose input/output 13 (default input) 2). LED module 5 Output
22	GPIO_14	DIO	1). General purpose input/output 14 (default input) 2). R8051 Timer 2 external input 3). LED module 6 Output
23	GPIO_15	DIO	1). General purpose input/output 15 (default input) 2). R8051 Timer 2 capture trigger input
29	XD0	DIO	1). R8051 port 3 bit 0 2). R8051 Timer 0 external input 3). R8051 SPI Master clock output / R8051 SPI Slave clock input 4). R8051 Compare/Capture input CC0 5). SPI Master clock output

30	XD1	DIO	<ol style="list-style-type: none"> 1). R8051 port 3 bit 1 2). R8051 Timer 1 external input 3). R8051 SPI Master data input / R8051 SPI Slave data output 4). R8051 Compare/Capture input CC1 5). SPI Master data output
31	XD2	DIO	<ol style="list-style-type: none"> 1). R8051 port 3 bit 2 2). R8051 external interrupt 0 3). R8051 SPI Master data output / R8051 SPI Slave data input 4). R8051 Compare/Capture input CC2 5). SPI Master data input
32	XD3	DIO	<ol style="list-style-type: none"> 1). R8051 port 3 bit 3 2). R8051 external interrupt 1 3). R8051 SPI Master slave select 0 output 4). R8051 Compare/Capture input CC3 5). SPI Master chip enable 0 output
33	XD4	DIO	<ol style="list-style-type: none"> 1). R8051 port 3 bit 4 2). R8051 serial 0 interface receive data, RXD0 3). R8051 SPI Master chip enable 1 output 4). R8051 Compare/Capture output CCBUS0 5). SPI Master chip enable 2 output
34	XD5	DIO	<ol style="list-style-type: none"> 1). R8051 port 3 bit 5 2). R8051 serial 0 interface transmit data, TXD0 3). R8051 SPI Master slave select 2 output 4). R8051 Compare/Capture output CCBUS1 5). SPI Master chip enable 3 output
37	XGPIO_0	DIO	<ol style="list-style-type: none"> 1). General purpose input/output 0 (default input) 2). I2S DAC4 master clock output
38	XGPIO_1	DIO	<ol style="list-style-type: none"> 1). General purpose input/output 1 (default input) 2). I2S DAC4 bit clock input/output
39	XGPIO_2	DIO	<ol style="list-style-type: none"> 1). General purpose input/output 2 (default input) 2). I2S DAC4 left/right clock input/output
40	XGPIO_3	DIO	<ol style="list-style-type: none"> 1). General purpose input/output 3 (default input) 2). I2S DAC4 serial data output for channel 0, 1
41	XGPIO_4	DIO	<ol style="list-style-type: none"> 1). General purpose input/output 4 (default input) 2). LED module 1 Output
42	XGPIO_5	DIO	<ol style="list-style-type: none"> 1). General purpose input/output 5 (default input) 2). LED module 2 Output
43	XGPIO_6	DIO	<ol style="list-style-type: none"> 1). General purpose input/output 6 (default input) 2). LED module 3 Output

44	XGPIO_7	DIO	1). General purpose input/output 7 (default input) 2). R8051 serial 0 interface receive data, RXD0
Control Interface			
47	XMSCL	DIO	1). I2C Master serial clock 2). R8051 I2C serial clock
48	XMSDA	DIO	1). I2C Master serial data 2). R8051 I2C serial data
49	XSSCL	DIO	1). I2C Slave serial clock 2). R8051 I2C serial clock (This function is disabled, if R8051 I2C is connected to XMSCL and XMSDA)
50	XSSDA	DIO	1). I2C Slave serial data 2). R8051 I2C serial data (This function is disabled, if R8051 I2C is connected to XMSCL and XMSDA)
Miscellaneous			
46	XRSTN	DI	Reset input, active low
51	XTEST	DI	Test mode input
52	N.C		No connection
53	N.C		No connection
54	N.C		No connection
56	N.C		No connection
57	N.C		No connection

AI: Analog Input

AO: Analog Output

AIO: Analog Input/Output

DI: Digital Input

DO: Digital Output

DIO: Digital Input/Output

7 Function Description

7.1 USB Topology

The CM6635 USB Topology is programmable by changing firmware. If the internal firmware is empty, the CM6635 will report a HID device to the system. It is use to load the firmware.

7.2 USB Endpoint

All USB devices must support a control pipe at endpoint number zero (default control pipe). The full speed and high speed devices may support up to a maximum of 16 endpoints. The endpoint table of CM6635 is listed as follows.

EndpointNumber	Direction	Type	Description
0	IN	Control	
	OUT		
1	IN	Bulk, Isochronous	Audio, Recording DMA #R5
	Out	Bulk A	
2	IN/OUT	Bulk B	
3	IN	Feedback	Audio, Playback DMA #P5
	OUT	Isochronous	
4	IN/OUT	Interrupt A	
5	IN	Feedback	Audio, Playback DMA #P0
	OUT	Isochronous	
6	IN		
	OUT		
7	IN		
	OUT		
8	IN	Isochronous	Audio, Recording DMA #R0
9	IN		
A	IN		
B	IN		
	OUT		
C			
D	IN		
E	IN	Isochronous	Audio, Recording DMA #R4
F	IN/OUT	Interrupt B	

7.3 I2S Interface

The main audio interface of the CM6635 is I²S, which has three clock signals, MCLK, BCLK and LRCK, and at least one data line depending on the channels supported. One data line contains two channels. The three I²S clock symbols are explained below.

MCLK = main clock.

BCLK = bit clock.

LRCK = left and right clock.

7.3.1 The Basics of I2S Bus

Both master and slave modes of I2S are supported by the I2S interfaces of the CM6635, namely I2S DAC0, I2S ADC0. Master mode means BCLK and LRCK are provided by the CM6635 as shown in Fig. 7.3.1(a). On the contrary, slave mode means BCLK and LRCK are provided by the I2S codecs as depicted in Fig. 7.3.1(b).

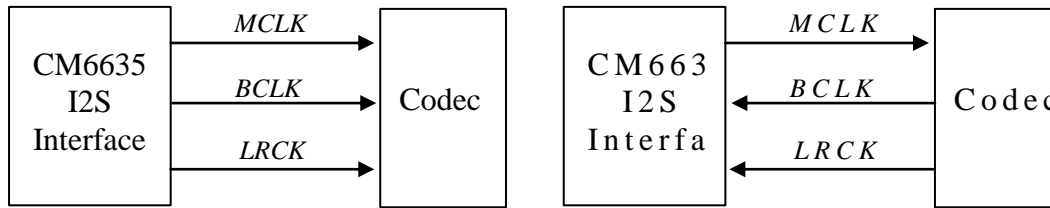

Fig. 7.3.1 (a) Master mode

Fig. 7.3.1 (b) Slave mode.

Fig. 7.3.2 indicates the basic waveform of I2S. Note that BCLK is generated at the positive edges of MCLK with the ratios 1, 1/2, 1/4, or 1/8, and LRCK is generated at the negative edges of BCLK with the ratios 1/64, 1/128, 1/256. Data bits are transited at the negative edges of BCLK, and are sampled at the positive edges of BCLK. In case of playback, CM6635 is the data transmitter and the codec is the data receiver. As for recording, the roles of CM6635 and codec are reversed.

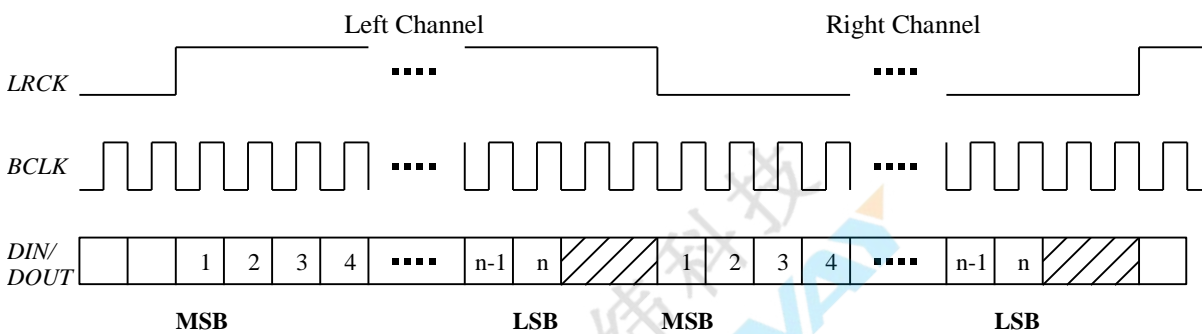

Fig. 7.3.2 The basic timing diagram of the I2S interface.

For the I2S DAC controller, the audio data is transformed from the parallel format to the serial format before transmitted. Then, the bit data is shifted out one by one with the MSB first via DOUT signal. If the I2S DAC controller is set to 32 bits, at least 32 BCLK clocks must exist in both LRCK left and right channels. In the same manner, the audio data is transformed from the coming serial format to the parallel format for a I2S ADC controller.

7.3.2 Left Justified Mode

In the left justified mode of the I2S DAC controller, the MSB data bit is clocked out by the CM6635 at the negative edge of BCLK which is aligned to the transition of LRCK. In the left justified mode of I2S ADC controllers, the MSB data bit is clocked out by codecs and sampled by the CM6635 at the first positive edge of BCLK which follows a LRCK transition. LRCK is high during left channel transmission and low during right channel transmission in the left justified mode. Fig. 7.3.2 shows all of these.

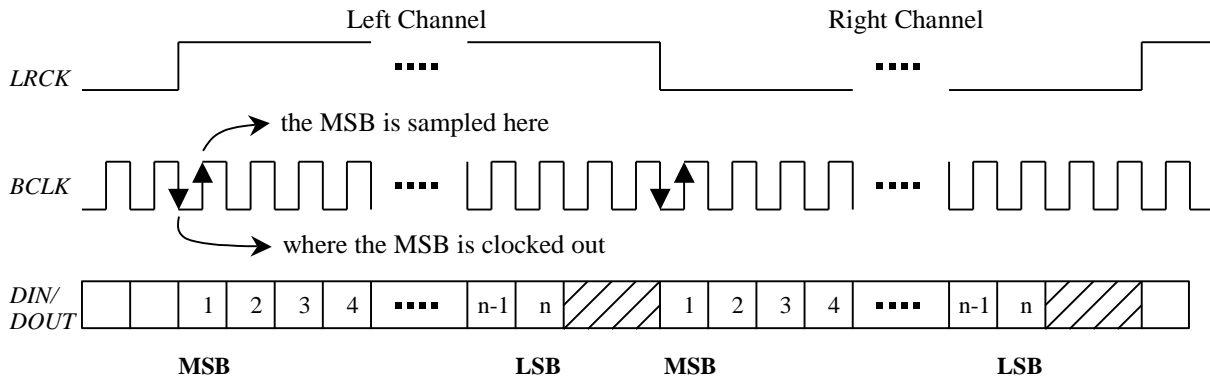

Fig. 7.3.2 Left justified mode timing diagram of I2S interface.

7.3.3 I2S Mode

In the I2S mode of the I2S DAC controller, the MSB data bit is clocked out by CM6635 at the first negative edge of BCLK which follows a LRCK transition. In the I2S mode of I2S ADC controllers, the MSB data bit is clocked out by codecs and sampled by the CMA6635 at the second positive edge of BCLK which follows a LRCK transition. LRCK is low during left channel transmission and high during right channel transmission in the I2S mode. Fig. 7.3.3 indicates all of these.

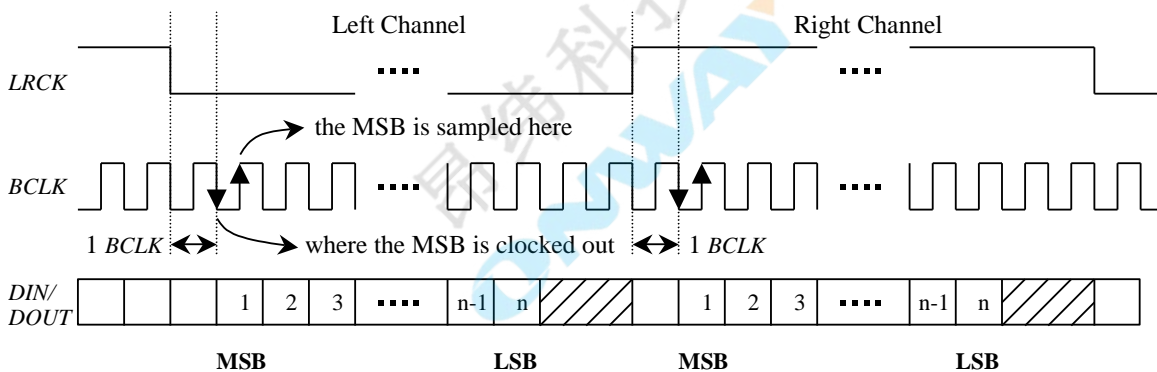

Fig. 7.3.3 I2S mode timing diagram of I2S interface.

7.4 S/PDIF Interface

SPDIF is an audio transmission format in digital domain. The data stream format is illustrated in Fig. 7.4.1. The maximum unit of the S/PDIF stream is a block. A block is composed of 192 frames, and each frame is composed of two subframes. One frame contains one audio sample, so the frame rate is equal to the sampling rate. The left channel audio data is carried by bit slot 4-27 (or time slot 4-27) of subframe A, and right channel is carried by bit slot 4-27 of subframe B. The Sync slot takes preamble signal which is used to label the beginning of a subframe. There are three types for preamble signal, the first is B type, used only in the first subframe of a block; the W type, used in all subframe B; the M format, used in all subframe A, besides the first subframe of a block. The block format is shown in Fig. 7.4.1. The logical level at the start of a bit is always inverted to the level at the end of the previous bit. The level at the end of a bit is equal (a 0 transmitted) or inverted (a 1 transmitted) to the start of that bit.

The S/PDIF data signal is coded by the “biphase-mark-code,” which is a kind of phase modulation. It is illustrated in Fig. 7.4.2. The base clock of a S/PDIF signal is twice the bit rate, and the frequency of the base clock is only

determined by the sampling rate. The period of the base clock is called the Unit interval (UI). For example, for a 48KHz 2-channel S/PDIF signal, the frame rate is also 48KHz, so a frame period is 20.833us, and a subframe period is 10.416us. A subframe contains 32-bit slot, so a bit slot period is 325.52ns. As we said above, the base clock is twice the bit rate. Therefore, the period of the base clock is 162.76ns. In other words, the frequency of base clock is 6.144 MHz. Bi-phase coding can prevent PCM data from DC isolated and insensitive to level polarity. A maximum up to 24 data bits can be transmitted by the S/PDIF signal, and the sequence is from LSB to MSB.

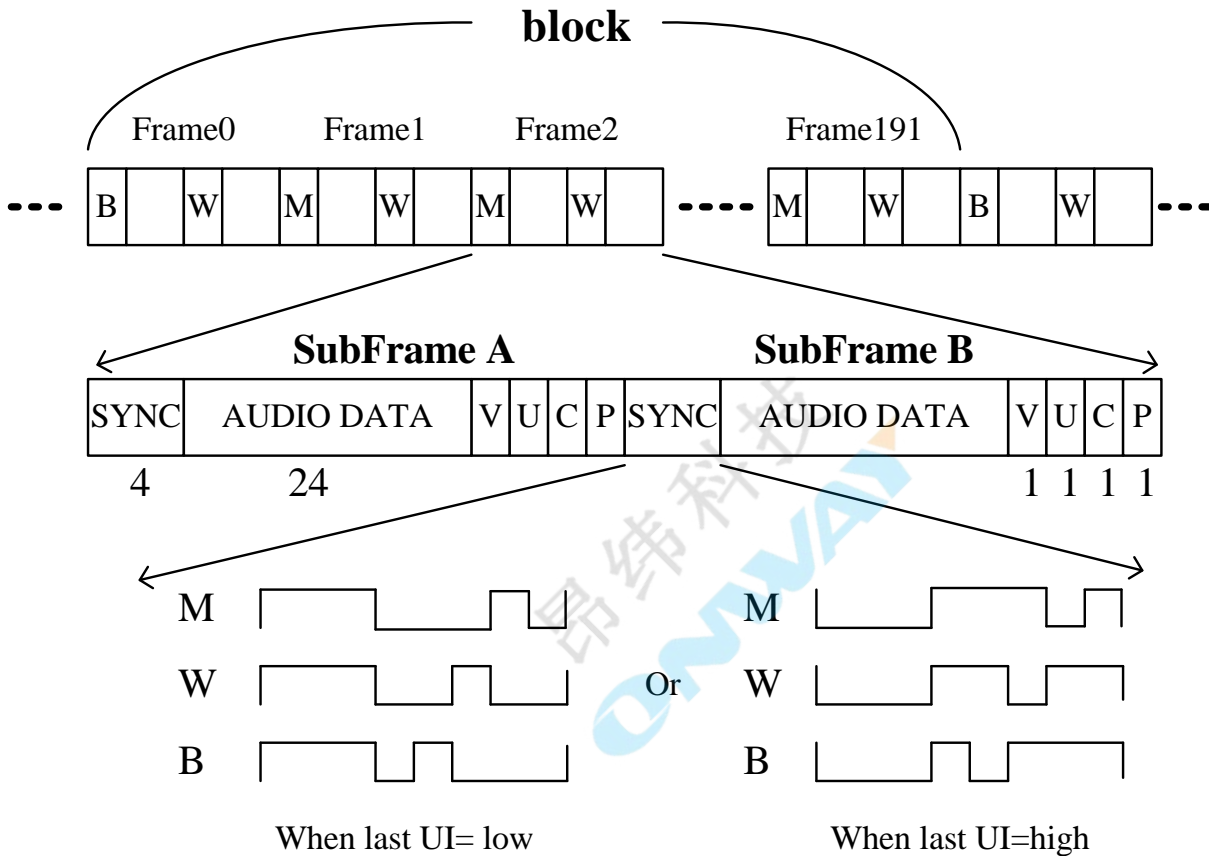

Fig. 7.4.1 S/PDIF Frame format.

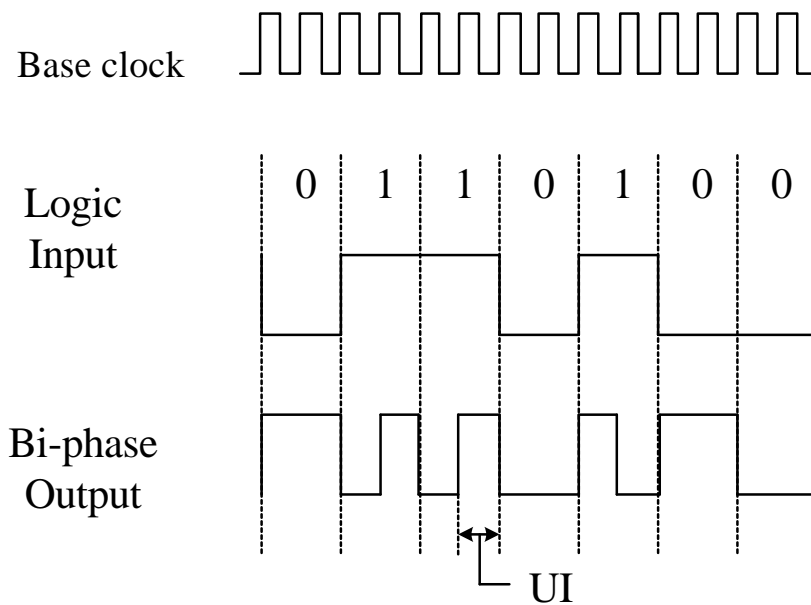

Fig. 7.4.2 S/PDIF biphasic-mark-code (BMC).

7.5 I2C, Two-Wire Interface

The 2-wire master and slave serial buses are designed separately in the CM6635. There are two reasons which let us make such a decision. The first reason is that the separated 2-wire master and slave buses are easier to design, and the second reason is that the 2-wire master bus pins have been shared with SPI interface. In the most applications, the SPI interface is the one that is chosen to control the codecs, so the 2-wire slave bus cannot combine with the 2-wire master bus.

7.5.1 The Concept of I2C, Two Wire Interface

The 2-wire bus, as its name reveals, has 2 lines. One is the serial clock line (*SCL*), and the other is the serial data line (*SDA*). Both of them are operated under open drain. That means if the 2 lines are not driven by a master or a slave, they are pulled high by the external pull-up resistors as indicated by Fig. 7.5.1. A device connected on the bus can be recognized as a master or a slave when performing data transfers. A master is the device which initiates a data transfer on the bus and generates the clock signals to permit that transfer. At that time, any device addressed is considered a slave. Another concept that we should know is the transmitter-receiver relation. *The transmitter is the device which sends data to the bus, and receiver is the device which receives data from the bus.* Note that the definition of transmitter-receiver is different from that of master-slave. We will use these terms to explain 2-wire read/write transactions later. The CM6635 use 7 bits to address the slave devices such as codecs, so theoretically, the 2-wire bus is able to connect 128 slave devices. However, in the audio system application, the limitation is on the codecs, not on the CM6635. Usually, the codecs which support 2-wire bus only have one or two pins to select their address. Therefore, two or four codecs is allowed in the system indicated by Fig. 7.5.1, unless the codecs are from different manufactures. In the MCU application, the CM6635 is a slave device, and it can be addressed by the MCU via four different addresses, 0001000b, 0001001b, 0001010b, 0001011b.

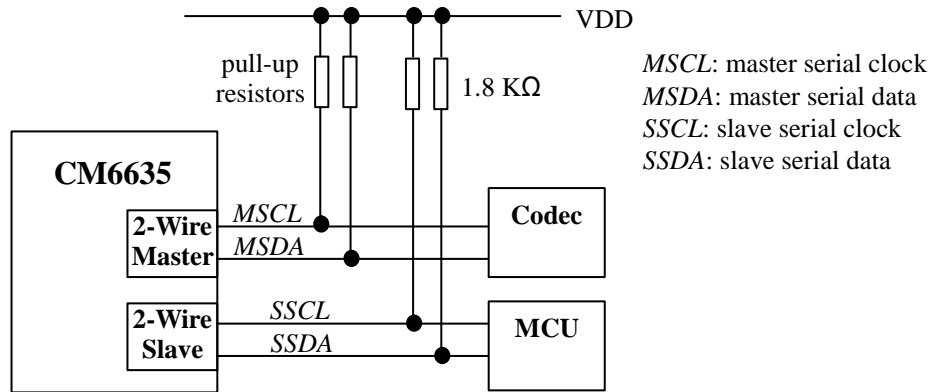

Fig. 7.5.1 The connection of 2-wire master and slave buses.

7.5.2 Start and Stop Condition

For a 2-wire bus transaction, the start and stop condition is defined as follows and shown in Fig.7.5.2.

- Start: a high to low transition on the *SDA* line while *SCL* is high.
- Stop: a low to high transition on the *SDA* line while *SCL* is high.

Start and stop conditions always generated by the master device. The bus is considered to be busy after the start condition. The bus is considered to be free again after the stop condition.

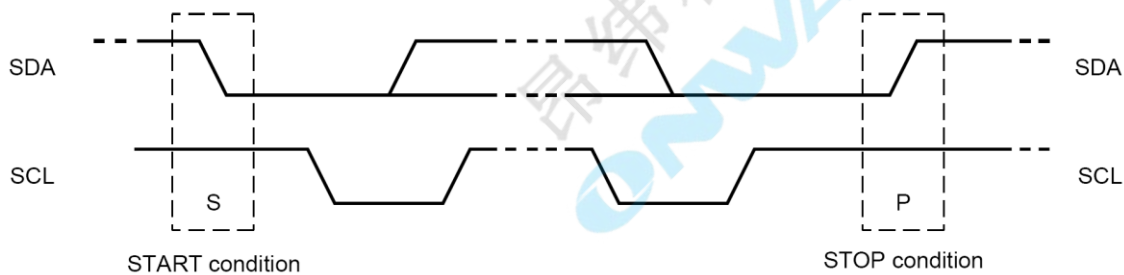

Fig. 7.5.2 Start and stop conditions of 2-wire bus.

7.5.3 Bit Transfer

The data on the *SDA* line must be stable during the high period of the clock. The state of the data line can only transit when the clock signal on *SCL* line is low. The bit transfer is indicated in Fig. 7.5.3.

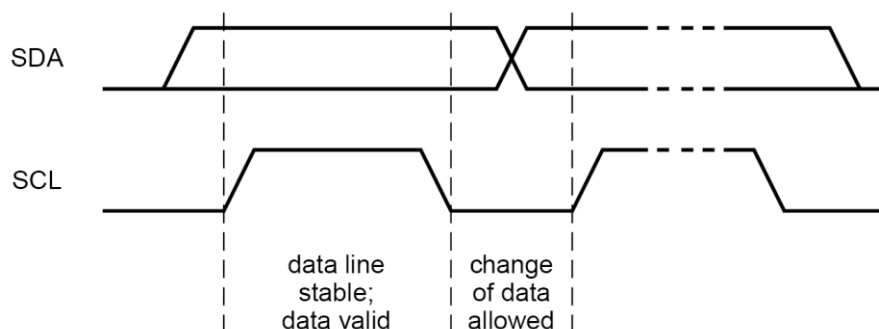

Fig. 7.5.3 Bit transfer of 2-wire bus.

7.5.4 Transferring Data with Read/Write Transactions and Acknowledge

Every byte put on the SDA line must be 8-bit long. The number of bytes that can be transmitted per transfer is 3 or 4 bytes in the CM6635. The first byte is always the address byte which is composed of the 7-bit address and 1 read/write bit, listed in Fig. 7.5.4.1 For a write transaction, the second byte is called *Memory Address Pointer (MAP)*, which is usually used to indicate the target register in the slave device that the followed third and fourth bytes will be applied on. For a read transaction (only 3 bytes), the second and third bytes is the data returned by the slave device. Each byte has to be ended by an acknowledge bit. Data is transferred with the most significant bit first.

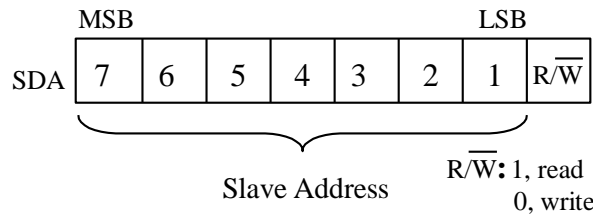

Fig. 7.5.4.1 The first byte after start condition.

The 2-wire master bus of the CM6635 supports read/write transactions. All these transactions are depicted in Fig. 7.5.4.2 to give a whole picture about what the CM6635 can do.

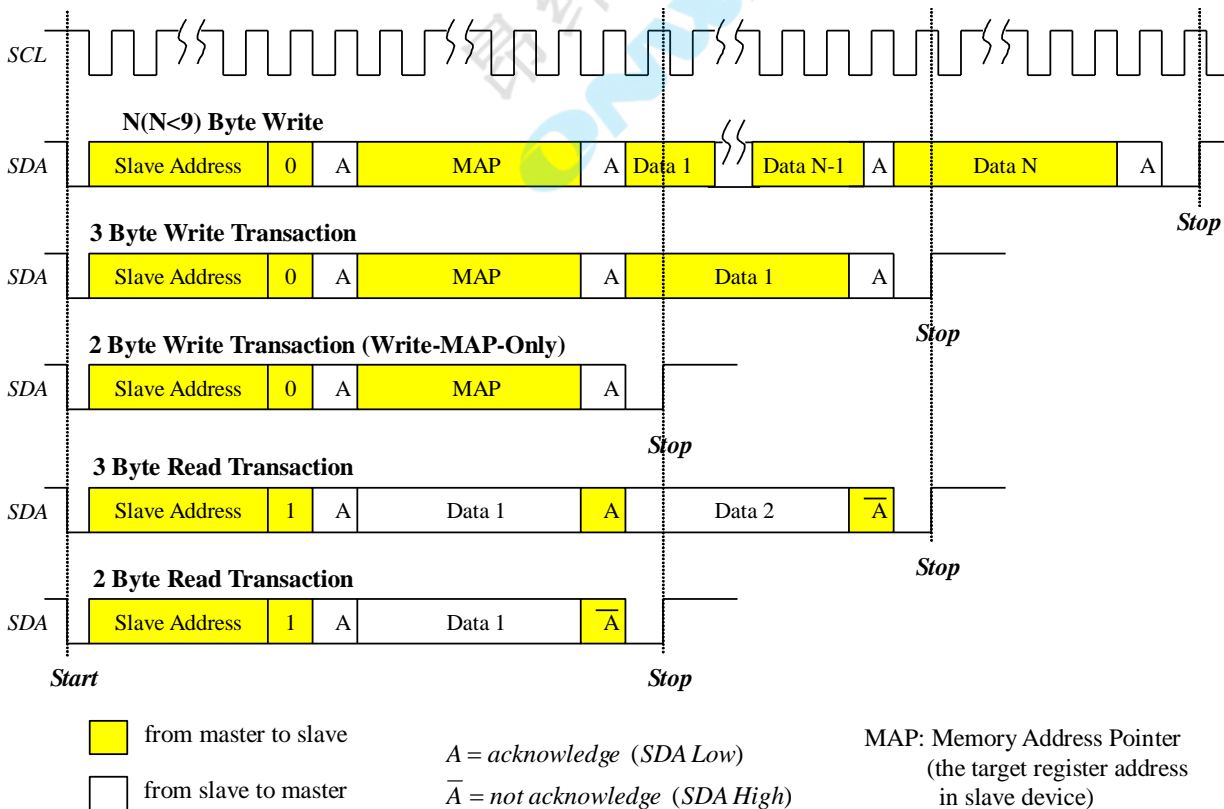

Fig. 7.5.4.2 The 5 basic transactions of the 2-wire master bus supported by the CM6635.

In a read transaction, usually the slave device returns the data of the register whose address is in the MAP. If the read transaction is a 3 byte read transaction, the second returned byte is the data in the (address+1) register. Therefore, the action of obtaining the data in slave device is composed of two transactions, namely a 2 byte write transaction (Write-MAP-Only) followed by a read transaction. For the convenience of users, we have designed an auto read transaction, shown in Fig. 7.5.4.3, which is actually the combination of a write and a read transactions.

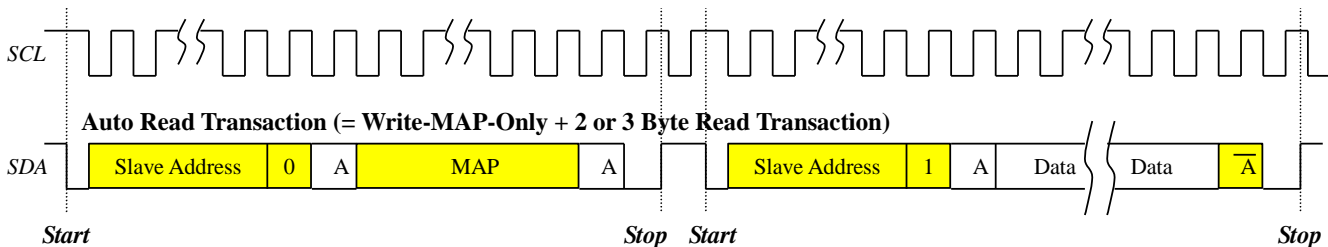

Fig. 7.5.4.3 Auto read transaction in the CM6635.

Data transfer with acknowledge is obligatory. The transmitter release SDA line during the acknowledge clock pulse. Then, the receiver must pull down the SDA line during the acknowledge clock pulse so that it remains low for the entire acknowledge clock high period. This is shown in Fig. 7.5.4.4. When a slave does not acknowledge the slave address byte. For example, it is unable to receive or transmit because it is performing some real-time function. The data line should be left high by the slave. The master can then generate either a stop condition to abort the transfer, or a repeated start condition to start a new transfer.

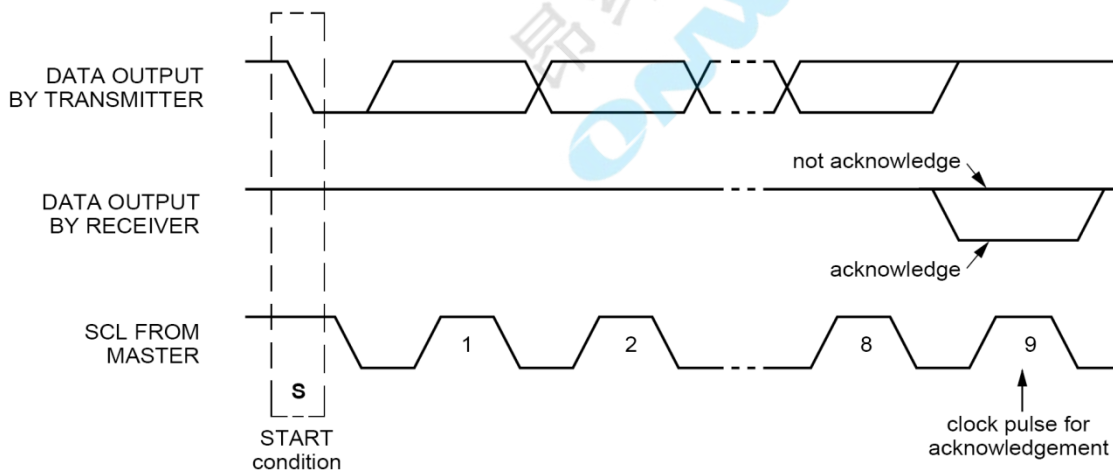

Fig. 7.5.4.4 Acknowledge of the 2-wire bus.

For a read transaction, after the slave address byte is transmitted and acknowledged by slave device, the role of master-transmitter is altered to become master-receiver, and the original slave-receiver is altered to become slave-transmitter. This conception can be easily observed in Fig. 7.5.4.3 and 7.5.4.4, where we use yellow and white blocks to denote the data bit transfer direction. Yellow means the data direction is from the master to the slave. White means the data direction is from the slave to the master. Meanwhile, in a read transaction, the master-receiver must signal the end of the data to the slave transmitter by generating a not-acknowledge (\bar{A}) on the last byte that was clocked out of the slave-transmitter. The slave-transmitter should release the SDA line to allow the

master to generate a stop or repeated start condition.

7.5.5 Synchronization

The synchronization of the 2-wire bus in the CM6635 can be described in two aspects. The first aspect is the synchronization used in arbitration. Although we did not implement arbitration, we did implement clock synchronization. Clock synchronization is used when there are more than two masters connected on the bus. A high to low transition on the *SCL* line will cause the concerned masters start counting the clock low period. Before the clock high state is reached, the masters will hold the *SCL* line in low state. However, the low to high clock transition of one of the masters may not change the state of the *SCL* line if another master's clock is still in low period (because the *SCL* line of the devices are wire-AND connected by open-drain technique). Therefore, the *SCL* line will be held low by the device with the longest clock low period. The other devices with shorter low period, including the CM6635, enter a high wait state during this time. Figure 7.5.5.1 listed below is the timing of clock synchronization.

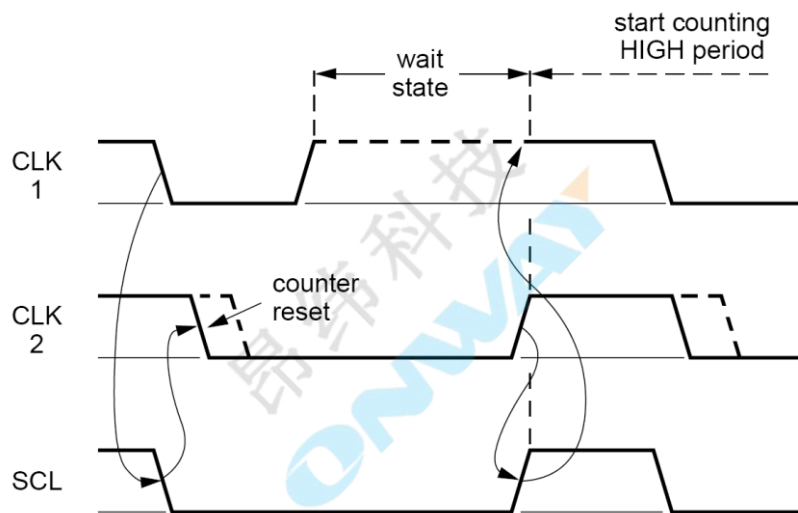

Fig. 7.5.5.1 Clock synchronization for more than two masters in the bus.

Another aspect of synchronization is the data synchronization between master and slave. If a slave cannot receive or transmit another complete byte of the data until it has performed some other function, for example servicing an internal interrupt or waiting for the driver to prepare the data needed, the slave can hold the clock line *SCL* low to force the master into a wait state. Data transfer then continues when the slave is ready and releases the clock line *SCL*. The data synchronization is shown in Fig. 7.5.5.2.

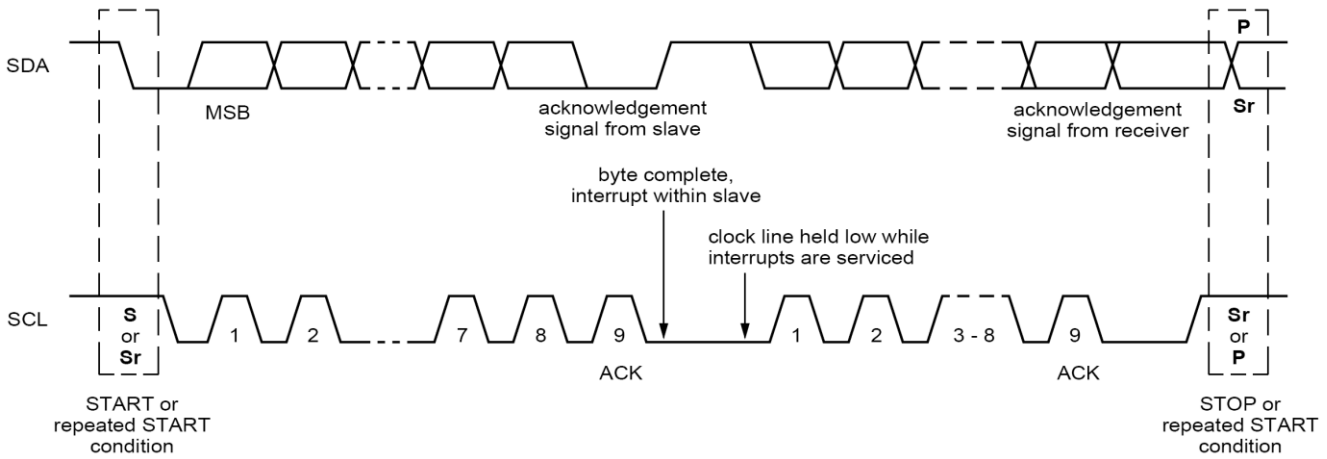

Fig. 7.5.5.2 The data synchronization of the 2-wire master and slave buses in the CM6635.

7.5.6 Standard Mode and Fast Mode

Both the 2-wire master and slave buses in the CM6635 can support standard mode transfer and fast mode transfer. The data transfer rate of the standard mode is up to 100 Kbits/sec, and the fast mode is up to 400 Kbits/sec. The clock timing of these modes are listed in Fig. 7.5.6 and Table 7.5.6

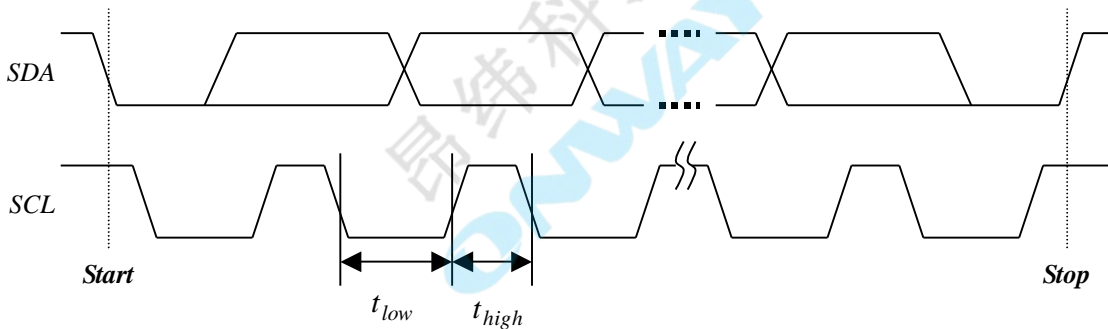

Fig. 7.5.6.1 Standard mode and fast mode timing.

Table 7.5.6 Standard mode and fast mode timing.

Parameter	Symbol	Standard mode		Fast mode		Unit
		MIN	MAX	MIN	MAX	
SCL clock frequency	f_{SCL}	0	100	0	400	KHz
Low period of SCL clock	t_{low}	4.8	—	1.3	—	μS
High period of SCL clock	t_{high}	4.8	—	0.6	—	μS

7.6 SPI Interface

The SPI128 module is a typical type of SPI interface for external SPI devices. It could most support 128 bytes in a SPI transfer. It supports 4 kinds of modes, which is two kinds of clock polarity and two kinds of phase polarity. Besides the typical SPI function for external SPI devices, the SPI128 module has the FIFO control function for wireless

applications. It could directly move in or out the SPI data to recording or playback SRAM through the SPI128 module internal 128 bytes SRAM.

7.6.1 The SPI128 interface Typical Transfer

The typical SPI128 Interface has 4 communication signals, which are SPI_DIN, SPI_DOUT, SPI_CLK and SPI_CEN. The SPI128 supports up to 8 external devices, user could use the chip select register to decide which one is selected. The SPI128 could configure the clock and phase polarity. Figure 7.6.1.1 and 7.6.1.2 describe the operation behaviors. When the clock polarity is set to zero (sckpol=0), means the SPI clock level is low when SPI is idle. When the clock polarity is set to one (sckpol=1), means the SPI clock level is high when SPI is idle.

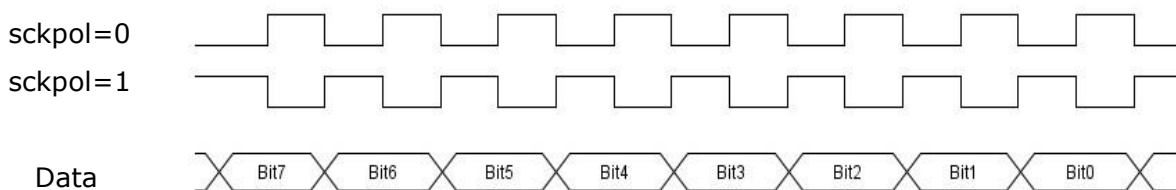

Fig 7.6.1.1, phase polarity = 0

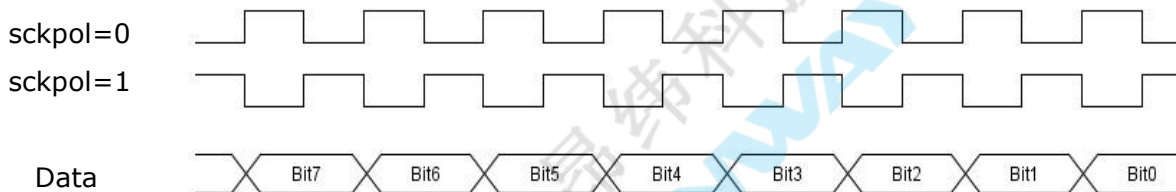

Fig 7.6.1.2, phase polarity =

- At sckpol=0: SPI clock level is low when SPI is idle
 - for phase polarity = 0, data are captured on the rising edge of SPI_CLK and data is propagated on the falling edge of SPI_CLK.
 - for phase polarity = 1, data are captured on the falling edge of SPI_CLK and data is propagated on the rising edge of SPI_CLK.
- At sckpol=1: SPI clock level is high when SPI is idle
 - for phase polarity = 0, data are captured on the falling edge of SPI_CLK and data is propagated on the rising edge of SPI_CLK.

For phase polarity = 1, data are captured on the rising edge of SPI_CLK and data is propagated on the falling edge of SPI_CLK.

7.7 GPIO

All the GPIO pins can be configured as input or output by the GPIO direction control registers and also can be configured as remote wake up input pin. If they are assigned as outputs, then the contents in the GPIO data registers will be reflected to the corresponding GPIO pins. If they are assigned as inputs, they can be used for jack activity detection. If a speaker is plugged or unplugged, the state of the pin connected with that jack will be changed. As a result, an interrupt is issued to R8051, and an interrupt mask control bit is utilized to decide if the interrupt from that corresponding GPIO pin should be sent. After receiving the interrupt, R8051 must read the GPIO data register (address offset 0x0300h) to discover what pins have changed their states. Then, the R8051 will make some appropriate manipulation in response to the jack activity.

CM6635 supports two kinds of Remote-wakeup. One is hardware Remote-wakeup, and the other is software Remote-wakeup. When in Configuration, CM6635 has to report the host via the descriptor whether CM6635 supports the Remote-wakeup or not. If CM6635 reports it supports Remote-wakeup and the host also supports Remote-wakeup, the host will issue the request of Set-feature to enable the Remote-Wakeup feature. If the user selects hardware Remote-wakeup, the user has to select one of the GPIOs to configure as a remote wakeup pin. If there is a transition from 0 to 1 on this pin, that will cause a remote-wakeup to wake up the host from the suspend state. The transition can be from outer world or from the control of the R8051. If the transition is from the control of the R8051, this is called Software Remote-wakeup. Software Remote-wakeup is implemented by the register. If the user selects software Remote-wakeup, the R8051 has to write the register to cause the transition from 0 to 1 to wake up the host.

CM6635 has a de-bouncing circuit to filter the interrupt to R8051. There are two options to select which are 16ms and 8ms. The user can select one option to use according to their application.

8 Electrical Characteristics

8.1 Absolute Maximum Ratings

Test conditions: DVDD50_IN = 5V, DVSS = 0V, TA = +25°C

Parameter	Symbol	Min.	Typ	Max.	Unit
Storage temperature	T _S	-25	-	150	°C
Operating ambient temperature	T _A	0	25	70	°C
Digital supply voltage(DVDD50_IN)	PWR	4.5	5.0	5.5	V
I/O pin voltage	-	GND	-	3.3	V
ESD (Body mode)	-	-	±4000	-	V
ESD (Machine mode)	-	-	±200	-	V

8.1 Recommended Operation Conditions

Parameter	Symbol	Min.	Typ	Max.	Units
Supply voltage(DVDD50_IN)	PWR	-	5	-	V
Digital Core(VDD)	PWR	1.2	1.25	1.38	V
Operating ambient temperature	-	-	25	-	°C
Crystal clock	-	-	12.000	-	MHz

8.2 Power Consumption

Test Conditions: DVDD50_IN, DVSS =0V, TA=+25°C, MCU Clock = 3MHz.
 Sample Rate=48kHz, 24Bits, Operation: I2S output and I2S input,
 I2S output and I2S input = Gain 0dB

Parameter	Symbol	Min.	Typ	Max.	Units
Total power consumption (Playback + Record)	-	-	48	-	mA
Standby power consumption	-	-	41.6	-	mA
Suspend mode power consumption	-	-	2.3	-	mA

8.3 DC Characteristics

Test Conditions: DVDD50_IN=5V, DVSS =0V, TA=+25°C

Parameter	Symbol	Min.	Typ	Max.	Units
High-level input voltage	Vih	2.4	-	5.3	V
Low-level input voltage	Vil	-	-	0.8	V
High-level output voltage	Voh	2.4	-	-	V
Low-level output voltage	Vol	-	-	0.4	V
SPDIF High-level input voltage	-	1.75	-	-	V
SPDIF Low-level input voltage	-	-	-	1.55	V

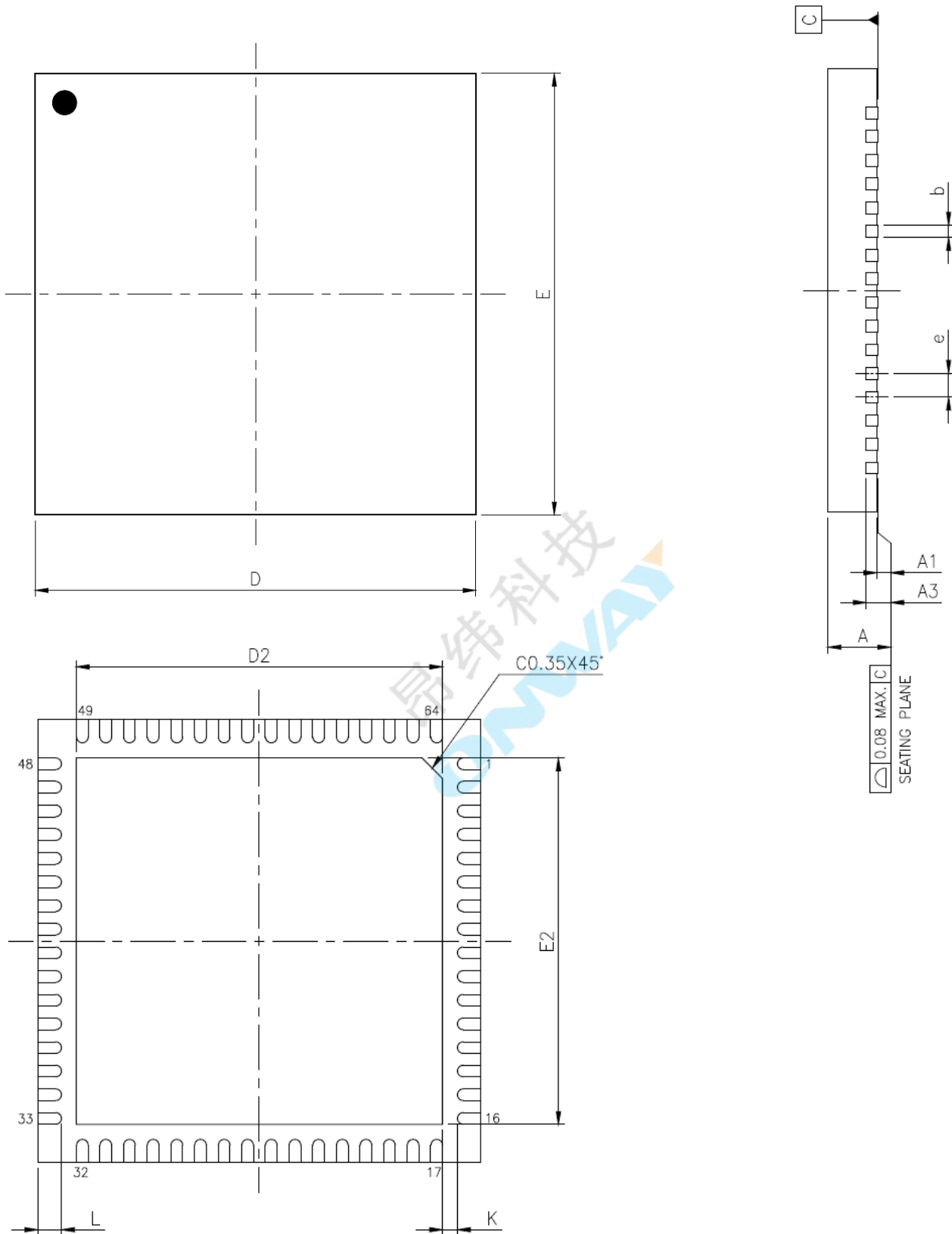
9 Package Dimensions

JEDEC OUTLINE	PACKAGE TYPE					
	N/A			N/A		
PKG CODE	WQFN(X764)			VQFN(Y764)		
SYMBOLS	MIN.	NOM.	MAX.	MIN.	NOM.	MAX.
A	0.70	0.75	0.80	0.80	0.85	0.90
A1	0.00	0.02	0.05	0.00	0.02	0.05
A3	0.203 REF.			0.203 REF.		
b	0.15	0.20	0.25	0.15	0.20	0.25
D	7.50 BSC			7.50 BSC		
E	7.50 BSC			7.50 BSC		
e	0.40 BSC			0.40 BSC		
L	0.30	0.40	0.50	0.30	0.40	0.50
K	0.20	—	—	0.20	—	—

PAD SIZE	D2			E2			LEAD FINISH		JEDEC CODE
	MIN.	NOM.	MAX.	MIN.	NOM.	MAX.	Pure Tin	PPF	
252X25* MIL	6.15	6.20	6.25	6.15	6.20	6.25	V	V	N/A

NOTES :

1. ALL DIMENSIONS ARE IN MILLIMETERS.
2. DIMENSION b APPLIES TO METALLIZED TERMINAL AND IS MEASURED BETWEEN 0.15mm AND 0.30mm FROM THE TERMINAL TIP. IF THE TERMINAL HAS THE OPTIONAL RADIUS ON THE OTHER END OF THE TERMINAL, THE DIMENSION b SHOULD NOT BE MEASURED IN THAT RADIUS AREA.
3. BILATERAL COPLANARITY ZONE APPLIES TO THE EXPOSED HEAT SINK SLUG AS WELL AS THE TERMINALS.

— End of Datasheet —

C-MEDIA ELECTRONICS INC.

6F., 100, Sec. 4, Civil Boulevard, Taipei, Taiwan 106 R.O.C.

TEL : +886-2-8773-1100

FAX : +886-2-8773-2211

E-MAIL : sales@cmedia.com.tw

Disclaimer:

Information provided by C-Media Electronics Inc. is sworn to be accurate and reliable. However, no responsibility is assumed by C-Media Electronics Inc. for its use, nor for any infringements of patents or other rights of third parties that may result from its use. Specifications are subject to change without notice. No license is granted by implication or otherwise under any patent or patent rights of C-Media. Trademarks, registered or not are the property of their respective owners.